

omega

installation
and operating
instructions



OA2416W
rangehood

English

WARNING

- The distance between the hob and the lower part of the hood must be at least 65 cm.
- The air collected must not be conveyed into a duct used to blow off smokes from appliances fed with an energy other than electricity (central heating systems, thermostats, water-heaters, etc.).
- Comply with the official instructions provided by the competent authorities in merit when installing the disposal duct. In addition, exhaust air should not be discharged into a wall cavity, unless the cavity is designed for that purpose.
- The room must be well aerated in case a hood and some other heat equipment fed with an energy other than electricity (gas, oil, coal heaters, etc) operate at the same time. In fact the intake hood, disposing of air, could create a vacuum in the room. The vacuum should not exceed 0,04mbar. This prevents the gas exhausted by the heat source from being intaken again. It is therefore advisable to ensure the room contains air taps able to ensure a steady flow of fresh air.
- **This appliance has such technical particulars that it belongs to class II insulation, therefore it must not be earthed.**

- The following warning is valid in the United Kingdom only: in case your cable is not furnished with a plug, read the following instructions; As the colours of the wires in the mains lead of this appliance may not correspond with the coloured markings identifying the terminals in your plug, proceed as follows:
 - the wire which is coloured blue must be connected to the terminal which is marked with the letter N or coloured black;
 - the wire which is coloured brown must be connected to the terminal which is marked with the letter L or coloured red.
 - neither wire is to be connected to the earth terminal of a three-pin plug.

- When making the electrical connections, check that the voltage values correspond to those indicated on the data plate inside the appliance itself.
In case your appliance is not furnished with a non separating flexible cable and has no plug, or has not got any other device ensuring omnipolar disconnection from the electricity main, with a contact opening distance of at least 3 mm, such separating device ensuring disconnection from the main must be included in the fixed installation. If your unit features a power led and plug, position this so the plug is accessible.
- Always switch off the electricity supply before carrying out any cleaning or servicing operations on the appliance.

USE

- Avoid using materials which could cause spurts of flame (flambées) near the appliance.
- When frying, take particular care to prevent oil and grease from catching fire. Already used oil is especially dangerous in this respect. Do not use uncovered electric grates.
- To avoid possible risks of fire always comply with the indicated instructions when cleaning anti-grease filters and when removing grease deposits from the appliance.

MAINTENANCE

- Thorough servicing guarantees correct and long-lasting operation.
- Particular care must be paid to the grease grille which must be periodically cleaned in relation to use (at least once every two months). Remove the grease grille and wash them either by hand or in the dishwasher using neutral detergent.
- Any fat deposits should be removed from the appliance periodically depending on amount of use (at least every 2 months). Avoid using abrasive or corrosive products. To clean painted appliances on the outside, use a cloth dipped in lukewarm water

and neutral detergent. To clean steel, copper or brass appliances on the outside, it is always best to use specific products, following the instructions on the products themselves. To clean the inside of the appliance, use a cloth (or brush) dipped in denatured ethyl alcohol.

■ HOW TO TAKE OFF THE GLASS

Before any cleaning or any servicing it is necessary to disconnect the apparatus.

To take off the glass, open the trolley pulling it frontwards; pull the glass towards the left (or the right) and lift one side upwards as it is indicated in the Figure 12.

DESCRIPTION

The appliance can be used in both the filtering and ducting version.

In the **Filtering** version (Fig. 1/2), the air and vapours conveyed by the appliance are depurated by activated charcoal fiber panel and recirculated around the room. **ATTENTION:** Using the hood as a filtering one it is necessary to use the activated charcoal fiber panel(s) that purifies the air sent back into the room.

In the **Ducting** version (Fig. 3), cooking vapours and odours are conveyed straight outside by a disposal duct which passes through the wall/ceiling. Use of activated charcoal fiber panel is therefore unnecessary.

According to the model you have bought, the appliance can include 1 or 2 motors. In the 1 motor version the flange for the air to be exhausted has not got a central position, but it is slightly on the left.

INSTALLATION

Before assembling, in order to manoeuvre the appliance more easily, take off the **grease grille** (Fig. 3): pull the front of the grille upwards; desinsert the back from its seat.

IMPORTANT: So as not to damage your product, during installation USE ONLY THE SCREWS PROVIDED. Make sure these are used as shown in the following instructions.

To compensate possible depth voids between the appliance and the wall, a plastic **SPACING BAR** to be fixed at the back of the appliance by means of the three screws **A** is included (Fig. 5). Cut the spacing bar according to the distance to be adjusted.

ASSEMBLY UNDER A PENSILE CUPBOARD

The following operations are essential for assembly:

- Install the wiring system
- Prepare the air venting hole if your appliance is to be installed in the Ducting version.

The filtering version of the apparatus can be assembled as indicated in Fig. 1, the air venting system being upwards, or as indicated in Fig. 2, the air venting system being frontwards.

For installation according to Fig. 2, do as follows:

1. Take off the air venting flange and put on the supplied tap **T** instead (Fig. 6).
2. Take off plate **P** unscrewing the 3 screws (Fig. 6).
3. Take off the front plate **F** unscrewing the 2 screws **A** (Fig. 6) and put a new plate according to your requirement (minimum height 80 mm).

Fixation as indicated in Fig. 7:

Using the relative template make the 4 necessary fixing holes in the bottom of the cupboard and cut the air venting hole: the opening for the air venting is not necessary for the filtering version of Fig. 2.

Move the hood close to the bottom of the wall unit and then connect the two units by means of the 4 self-tapping screws supplied together with the appliance.

Fixation with brackets as in Fig. 8 (optional):

Take the two brackets (**S**) out of the accessory bag together with the 8 screws provided. Fit the brackets to the wall unit being careful to position these correctly; for this operation use the 4 longer screws. At this point, secure the appliance to the brackets using the 4 shorter screws.

Ducting version: connect the flange of the hood with the air venting hole made previously in the wall/ceiling by means of an adequate tube. Make the electrical connections. Assemble the anti-grease grille with the hood, inserting it obliquely (making the front side go upwards).

Filtering version: make the electrical connections. Set the fiber panel inside the anti-grease grille blocking it by means of the 2 supplied metal wires (F), as indicated in Fig. 4. Assemble the anti-grease grille with the hood, inserting it obliquely (making the front side go upwards).

OPERATION

Controls of Fig. 9:

Switch C: position M (motor): the motor switches ON/OFF by opening/closing the truck; the lights are always OFF.

Position T (total): the motor and the lights switch ON/OFF by opening/closing the truck.

Position L: the lights switch ON and the motor switch OFF either if the truck is open or closed; the motor is always OFF.

Switch B: it select the speed of the motor.

When the switch is in M or T position, opening the truck, the motor starts working automatically at the selected speed.

Controls of Fig. 10:

Switch D: position A (automatic), the motor and the light are automatically regulated ON or OFF by the opening/closing of the truck.

Position M (manual), the light is on.

Position 0, the light is off.

Opening slightly the truck, the motor works at the I speed; opening a bit more, the motor works at the II speed; opening totally the truck, the motor works at the III speed.

In case the hood is a **filtering version** one, it is necessary to change the activated charcoal fiber panel according to utilization about every six month. To remove the fiber panel A (Fig. 4):

- open the truck pulling it the front.
- take off the anti-grease grill: pull the front of the grille upwards; desinsert the back from its seat.
- take off the fiber panel from the inside of the anti-grease grille taking off the 2 metal wires F (Fig. 4) that blocks it.

If the **light bulbs** need changing, slacken the light cover by disconnecting the screw and remove the bulb itself (Fig. 11). Replace with a bulb of the same type.

Deutsch

MONTAGE UND GEBRAUCHSANWEISUNG

- *Das Gerät ist so zu montieren, daß der Abstand zwischen den Kochplatten und dem unteren Rand der Dunstabzugshaube mindestens 65 cm beträgt.*
- *Ein Anschluss der Abluftleitungen an Verbrennungsabgaskamine (zum Beispiel Zentralheizung, Heizgeräte, Badezimmeröfen usw.) ist nicht gestattet.*
- *In jedem Fall sind bei der Ableitung der Abluft die behördlichen Vorschriften zu beachten. Desweiteren darf die Abluft nur dann durch ein Loch in der Wand geleitet werden, wenn dieses für diesen Zweck bestimmt ist.*
- *Achtung! Bei gleichzeitigem Betrieb einer Abluft-Dunstabzugshaube und einer raumluftabhängigen Feuerstätte (wie z. B. gas, öl- oder kohlebetriebene Heizgeräte, Durchlauferhitzer, Warmwasserbereiter) ist Vorsicht geboten, da beim Absaugen der Luft durch die Dunstabzugshaube dem Aufstellraum die Luft entnommen wird, die die Feuerstätte zur Verbrennung benötigt. Ein gefahrloser Betrieb ist möglich, wenn bei gleichzeitigem Betrieb von Haube und raumluftabhängiger Feuerstätte im Aufstellraum der Feuerstätte ein Unterdruck von höchstens 0,04 mbar erreicht wird und damit ein Rücksaugen der Feuerstättenabgase vermieden wird. Daher den Raum mit Lüftungsanschlüssen versehen, die einen konstanten Zustrom von Frischluft gewährleisten.*
- *Dieses Gerät weist konstruktive technische Details auf, die unter die Isolierungsklasse II fallen und deshalb muss es nicht geerdet werden.*
- *Beim elektrischen Anschluss muss überprüft werden, ob die Spannungswerte des Stromnetzes mit den Werten auf dem im Innern des Gerätes angebrachten Typenschildes übereinstimmen. Falls Ihr Gerät nicht mit einem fest angeschlossenem Kabel mit Stecker oder einer sonstigen Vorrichtung, die eine allpolige Unterbrechung mit einer Kontaktöffnung von mindestens 3 mm*

1

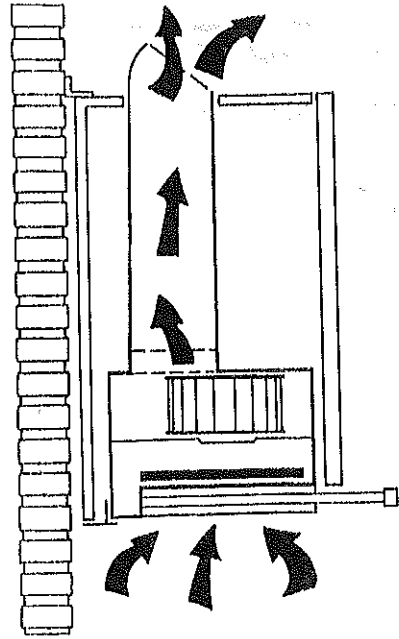

2

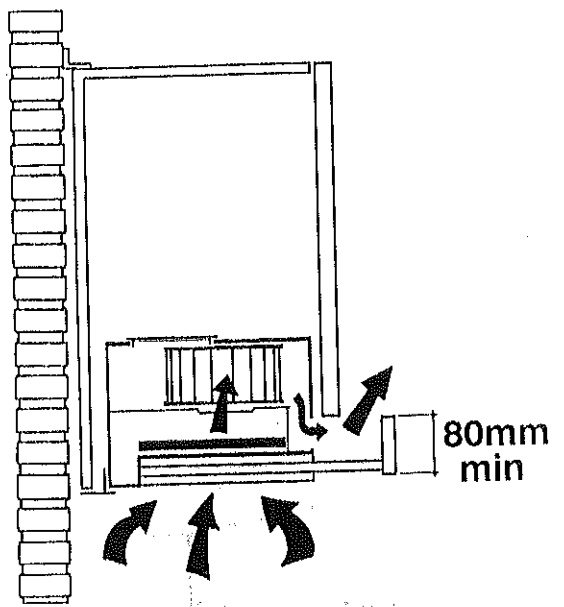

3

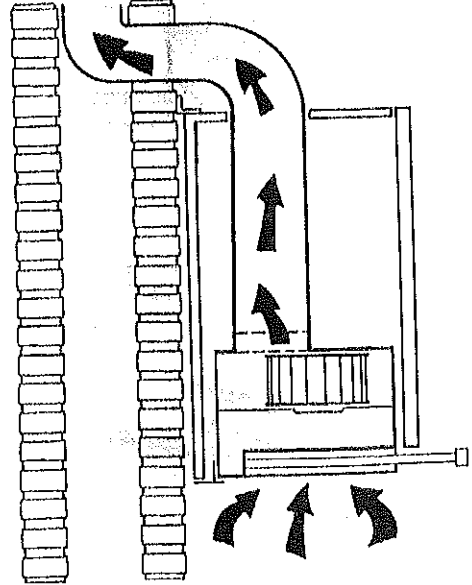

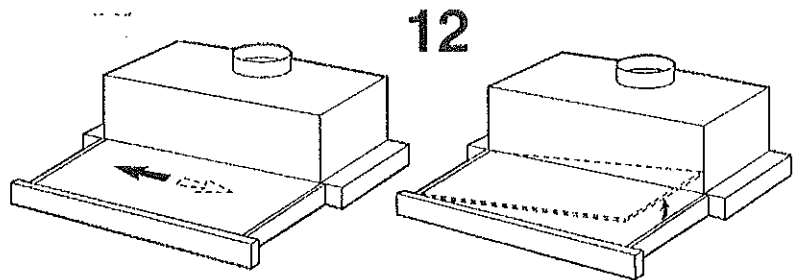
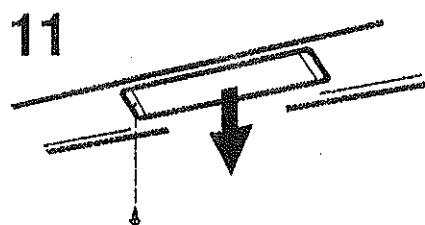
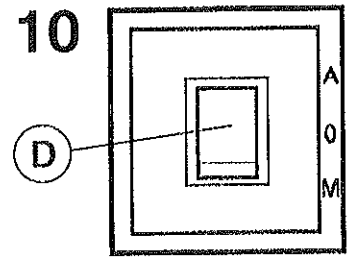
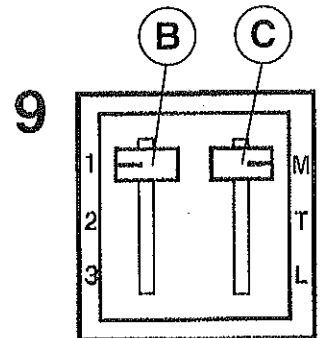
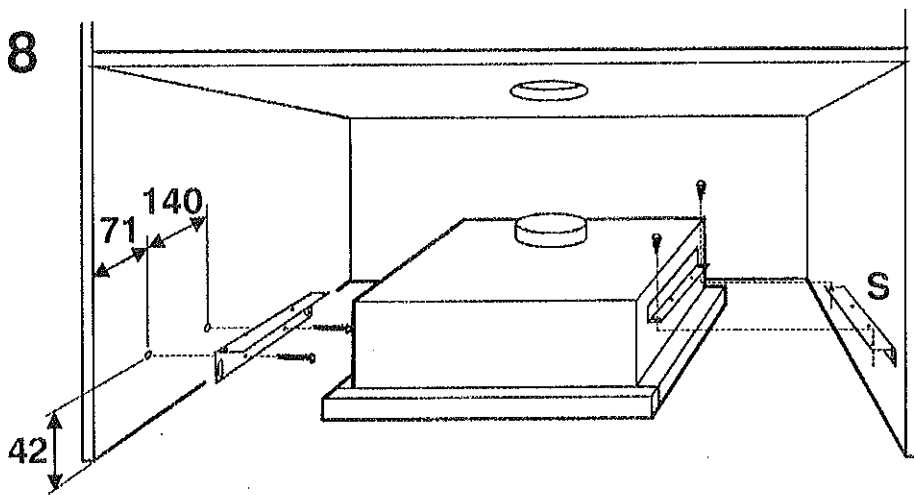
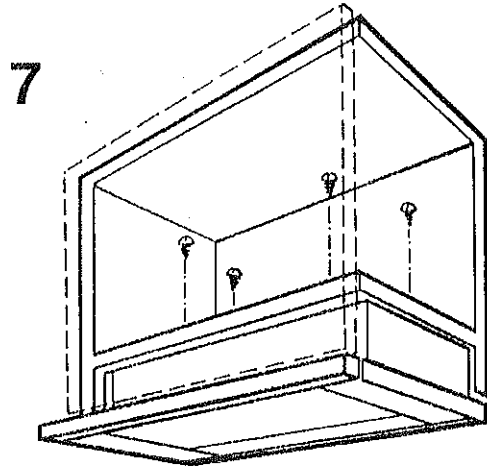
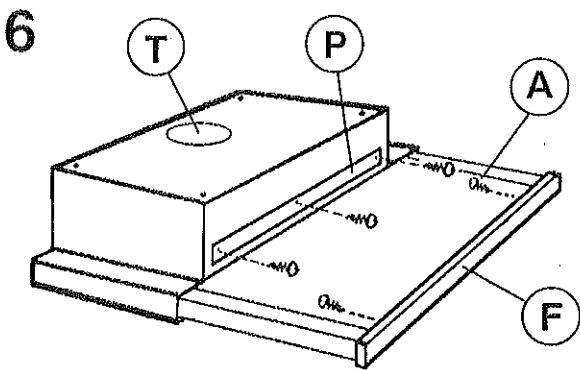
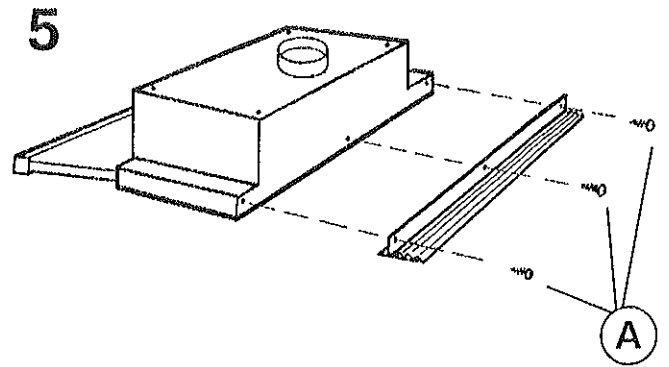
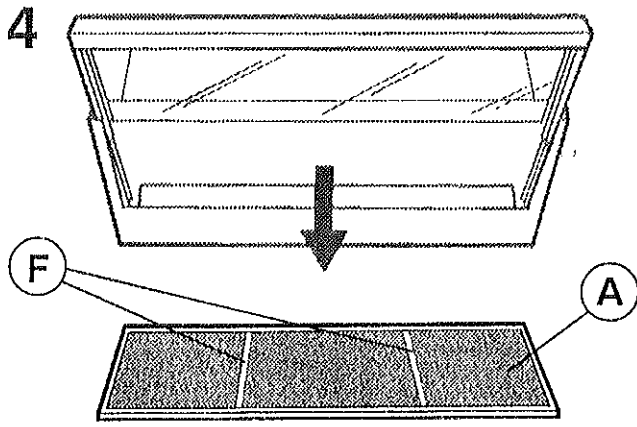

ENGLISH

If the **light bulbs** need changing, slacken the light cover by disconnecting the screw "A" and remove the bulb itself.

DEUTSCH

Um die **Lampe** austauschen zu können, muß zunächst die Lichtabdeckung durch die Umdrehung der Schraube "A", entfernt werden.

FRANCAIS

Pour accéder à l'**ampoule d'éclairage**, retirer le cache-lumière en dévissant la vis "A".

ITALIANO

Per sostituire le **lampade** di illuminazione rimuovere la plafoniera dopo aver disinsertito la vite di fermo "A".

ESPAÑOL

Para sustituir las **bombillas de iluminación** quitar el plafón después de haber destornillado el tornillo "A" que lo fija.

PORTUGUÊS

Para substituir as **lâmpadas de iluminação** remover a cobertura das lâmpadas depois de ter tirado o parafuso "A" de fixação.

NEDERLANDS

Voor vervanging van de **lamp** van de verlichting, verwijder het doorzichtige plaatje nadat de sluitschroef "A" is losgedraait.

SUOMI

Lampun vaihto. Poista lampun suojus kiertämällä auki ruuvi "A".

