

# omega

installation  
and operating  
instructions



omega  
OR905CRXA  
wallmount  
rangehood

## ENGLISH

### DESCRIPTION

The unit can be found in filtering hoods, exhaust hoods or in hoods with an outside motor. In the **Filtering** hoods (Fig. 1) the air and steam taken up by the unit are purified with charcoal filters and returned to the environment through the aeration grids on the side of the flue. **WARNING:** When using filtering hoods, both charcoal filters and an air deflector must be used. Located in the upper part of the flue, this deflector recycles the air to the environment (Fig. 1A). In the **Exhaust** hoods (Fig. 2) an exhaust duct conveys the steam and cooking odors directly outside through the wall/ceiling. Therefore they do not require charcoal filters. In the hoods with an **outside motor** (Fig. 3), a vacuum suction unit must be connected; this exhaust will operate separately, conveying the exhaust air through the unit. **Only use vacuum units suggested in the original catalogue.**

### INSTALLATION

To facilitate installation, before starting remove the **grease filter/s**: press inward on the clamp at the handle and pull the filter downward (Fig. 4/5).

**Installation of a utensil holder** (upon request): See Figure 6A or 6B depending on the model purchased. Install the utensil holder with 4 flathead screws (supplied). Secure the 2 supports (C) to the hood, one on the left and one on the right; insert the utensil holder into these supports. Keep a good grip on it until you have installed, and secured, at least one of the 2 supports (D) at the top of the hood.

**Installation on the wall** (Fig. 7): Using the special drilling template, drill the required holes in the wall. As previously specified in the chapter "Warning" remember there must be a minimum of 650 mm between the bottom edge of the hood and the top of the stove. Secure the metal bracket (B) to the wall using the screws and plugs (bracket, screws and plugs are all supplied with the unit). Use the 2 triangles cut into the bracket to position it precisely along the vertical axis of the hood. Then set the hood onto the bracket. Adjust the horizontal position, shifting the hood to the right or left as needed lining it up with the wall units. If the height of the hood also requires adjustment, use the special regulation screws (V) (supplied). Once regulation has been completed, finish securing the hood with 4 more screws (M); mark the points for the 4 holes on the wall, remove the hood and drill (8mm diameter holes); then use the plugs and screws to complete installation.

**Installation with rear panel** (Fig. 8): The rear panel is positioned at the top of the stove, flush against the wall. Rest the lower edge of the panel behind the stove and anchor the upper edge to the wall using the two holes found on the panel. Insert the screws and plugs provided (A). The unit is secured to the rear panel as though it were being installed on the wall: use the supplied metal bracket (B) and the screws and plugs supplied with the panel.

**Securing the extension flues:** Basic installation requirements: – Set the electrical power supply within the space covered by the decorative flues. – If your unit is installed in an Exhaust hood or in a hood with outside motor, prepare the air exhaust hole.

When installing exhaust hoods and hoods with outside motor, to achieve the best possible conditions use an **air exhaust pipe** that : i) is as short as possible, ii) has a minimum of curves (maximum angle: 90°), iii) is made of a material that complies with the standards (which vary from nation to nation) and iv) is smooth on the inside. It is also advisable to avoid any drastic changes in pipe section (diameter: 150 mm).

Adjust the width of the extension flue support bracket (W) using screws A indicated in Fig. 9. Then use the plugs and screws provided to secure it to the ceiling. Make certain it is aligned with the hood. For filtering hoods, the air exhaust grids are positioned in the upper part (Fig. 10). For exhaust hoods, turn the upper flue over so that the air exhaust grid is in the lower section (Fig. 11).

**Be very careful when handling the telescopic flues, especially when resting these on the hood body, to prevent scratching.**

**Exhaust hoods and hoods with outside motors:** Connect the hood flange to the exhaust hole in the wall/ceiling using a flexible pipe. Only for models with outside motor (Fig. 12): plug the hood into the outside control unit using the special terminal block: remove wire clamp A and lid B from the wiring junction box. Secure the wire connecting the control unit to terminal C. Then replace wire clamp A and lid B on the wiring junction box. The other end of the wire is secured to the terminal block on the outside control unit. Plug in the hood. Insert the extension pipes setting them on the hood; extend the upper flue to the ceiling and secure with the 2 screws (G) - Fig. 13.

**Filtering hood:** Secure the deflector to the upper flue using the 4 special screws (provided) – Fig. 14; hook up the flexible pipe (diameter: 125) to the deflector. Install the reduction (provided) on the hood air outlet point (Fig. 15). Take the 2 assembled extension flues and set them on the hood; extend the upper flue to the ceiling and secure with the 2 screws (G) - Fig. 13. Extend the lower flue taping it in place and then connect the flexible pipe to the hood reduction. Plug in the hood. Extend the lower flue downward setting it against the hood. Install the charcoal filters by pressing the 2 tabs on the filter down into the special housing (Fig. 16) and rotating upward.

### OPERATION

Depending on the model, the unit is equipped with the following controls:

**Controls shown in Fig. 17:**

Button **A** = turns the lights on/off.

Button **B** = turns the **TIMER** on/off: press once to turn the timer on, therefore, after 5 minutes, the motor cuts out (at the

same time the selected speed blinks on the display); the timer remains on if the motor speed is changed.  
Display **C** = - indicates the selected motor speed (from 1 to 4); - indicates Timer On when the number blinks; - indicates Filter Alarm when the central segments is on or blinking.  
Button **D** = makes the motor work (at the last speed selected); pushing the button again, the speeds of the motor are sequentially selected from 1 to 4; keeping this button pressed for about 2 seconds shuts down the motor.  
Button **R** = resets the grease filters or charcoal filters; when the filter alarm appears (i.e. when the central segment on the display goes on), the grease filters must be cleaned (30 hours of operation); when the central segment starts blinking, the grease filters must be cleaned and the charcoal filters replaced (120 hours of operation). Obviously, if the hood is not a filtering model and does not have a charcoal filter, clean the grease filters both when the central segment goes on and when it starts blinking. The filter alarm can be seen when the motor is off and for about 30 seconds. To reset the hour counter, keep the button pressed for 2 seconds while the alarm can be seen.

**Controls shown in Fig. 18/19:**

Switch **A**: LIGHT; position 0: light off; position 1: light on.

Switch **B**: MOTOR SPEED; makes it possible to select the motor operating speed; position 0: motor off.

**C**: Motor on light.

**Controls shown in Fig. 20:**

**A** = light switch.

**B** = first speed motor ON/OFF switch.

**C** = second speed switch.

**D** = third speed switch.

**E** = motor on light.

**Controls shown in Fig. 21:**

**Button A**: turns the lights on/off; every 30 hours of operation the corresponding pilot lamp (S) comes on to indicate that the grease filters must be cleaned; every 120 hours of operation the corresponding pilot lamp (S) flashes to indicate that the grease filters must be cleaned and the charcoal filter replaced. To restart the hour counter (RESET), hold the button A pressed down for about 1" (while the pilot lamp S is on).

**Button B**: drives the motor in first speed (the corresponding pilot lamp comes on); when holding it down for about 1", the motor cuts out; when pressing the button a second time (while the pilot lamp is on), the TIMER is activated and thus the motor stops after 5' (the pilot lamp flashes).

**Button C**: drives the motor in second speed (the corresponding pilot lamp comes on); when pressing the button a second time (while the pilot lamp is on), the TIMER is activated and thus the motor stops after 5' (the pilot lamp flashes).

**Button D**: drives the motor in third speed (the corresponding pilot lamp comes on); when pressing the button a second time (while the pilot lamp is on), the TIMER is activated and thus the motor stops after 5' (the pilot lamp flashes).

**Button E**: drives the motor in fourth speed (the corresponding pilot lamp comes on); when pressing the button a second time (while the pilot lamp is on), the TIMER is activated and thus the motor stops after 5' (the pilot lamp flashes).

**Pay special attention to the grease filters:**

if the model purchased has the controls shown in Figure 17: the grease filters must be cleaned approximately once every 30 hours of operation (when the central segment on the display goes on or starts blinking). To remove the filters: press inward on the clamps at the handles and pull the filter downward. Wash out the filter using a neutral soap. Once the cleaned filters are reinstalled, keep button R (Reset) pressed for two seconds to reset the counter. For further information, see the Controls in Fig. 17 in the paragraph entitled "Operation".

if the model purchased has the controls shown in Figure 18/19/20: the grease filter must be cleaned periodically: exactly how often depends on use (at least once every other month). To remove the filter: push inward on the clamp at the handle and pull the filter downward. Wash out the filter using a neutral soap.

if the model purchased has the controls shown in Figure 21: the grease filters must be cleaned approximately once every 30 hours of operation (when the light button lamp comes on) - Fig. 21S). To remove the filters: press inward on the clamps at the handles and pull the filter downward. Wash out the filter using a neutral soap. Once the cleaned filters are reinstalled, to reset the counter hold the light button pressed down for about 1" (Fig.21A) while the corresponding pilot lamp (S) is on. For further information, see the Controls in Fig.21 in the paragraph entitled "Operation".

**Replacing the charcoal filters:**

If the unit is a filtering hood, the **charcoal filters** must be replaced: to remove them press inward on the clamp (Fig. 16) and rotate the filter downward until the 2 tabs can be removed from the housing.

If the model purchased has the controls shown in Figure 17, the charcoal filters must be replaced whenever the central segment of the display starts blinking (i.e. every 120 hours of operation). If the model purchased has the controls shown in Figure 18/19/20, the charcoal filters must be replaced according to use: on the average once every 6 months. If the

model purchased has the controls shown in Figure 20. the charcoal filters must be replaced each time the light button (Fig.20S) lamp flashes (i.e. every 120 hours of operation).

**Lighting:** Depending on the model purchased, see Fig.22, Fig.23 or Fig. 24.

Fig. 22: to remove the **halogen lamps**, turn the locknut counter-clockwise. Replace with the same type of lamp.

Fig. 23: to replace the **incandescent light bulbs**, remove the grease filters so as to be able to access the inside of the unit; remove the screw securing the light fitting and then, working from inside the hood, push the light fitting pin towards the inside of the unit. Replace with light bulbs of the same type.

Fig. 24: if your appliance has the same kind of lights as in the figure 24, to replace the **incandescent light bulbs** open the grease grille and remove it; replace with light bulbs of the same type.

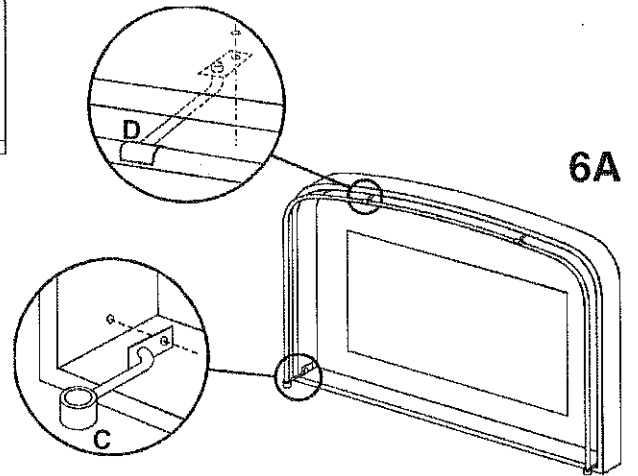
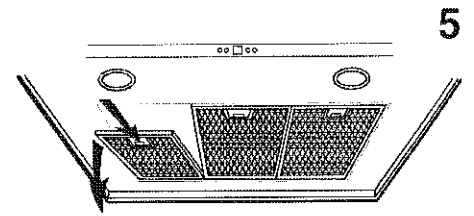
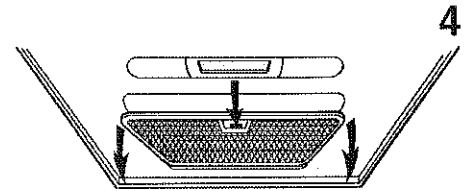
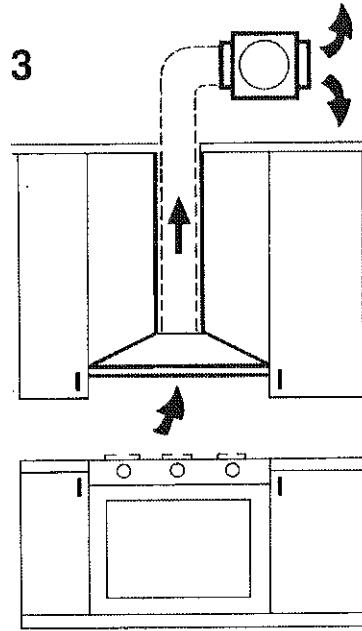
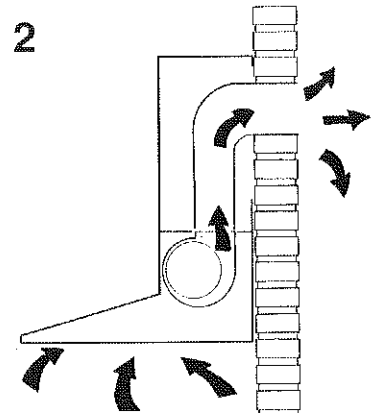
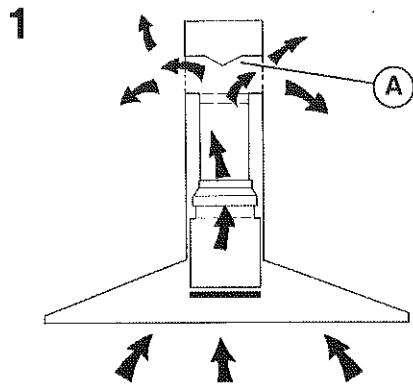

6B

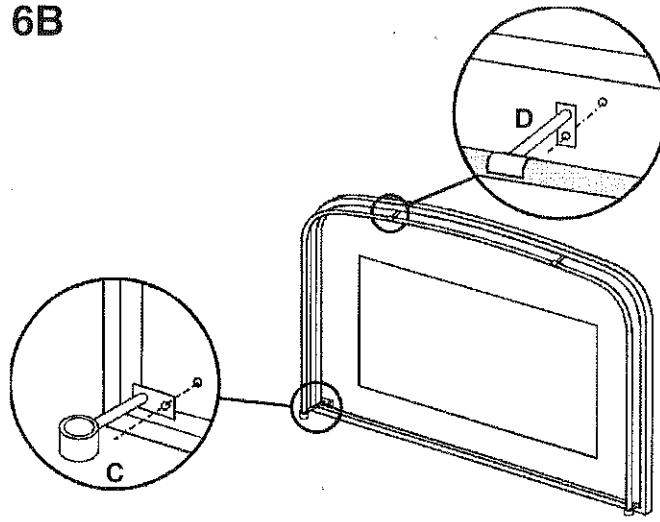

7

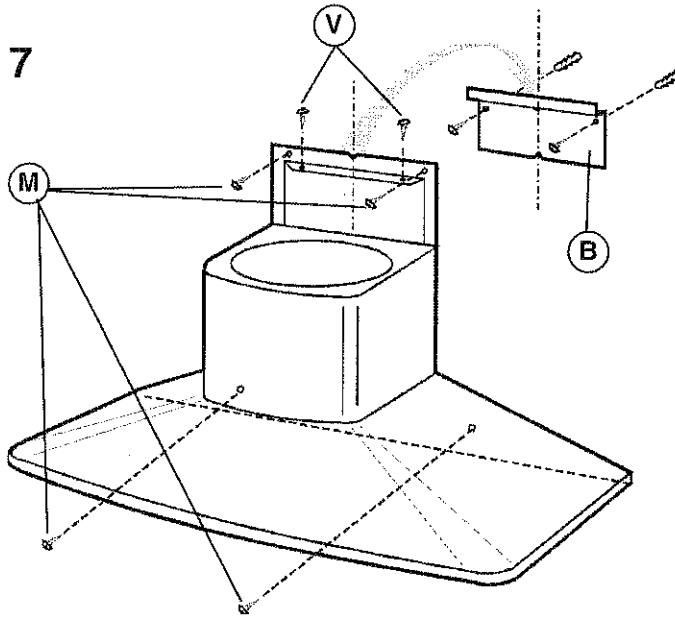

8

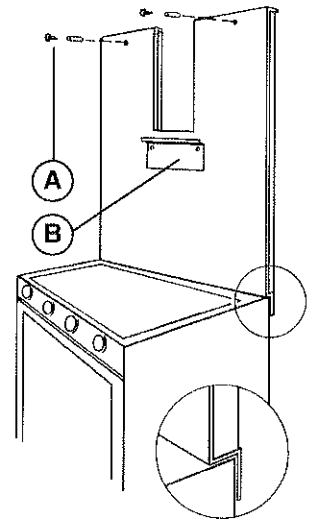

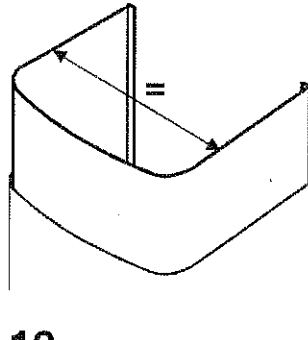
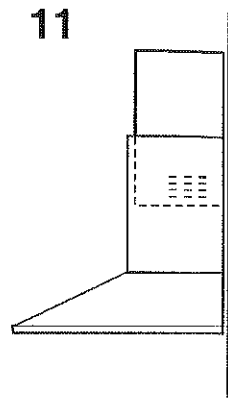
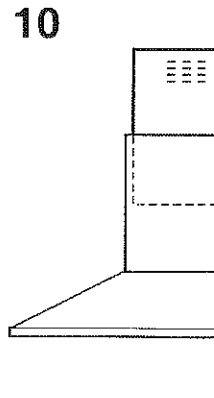
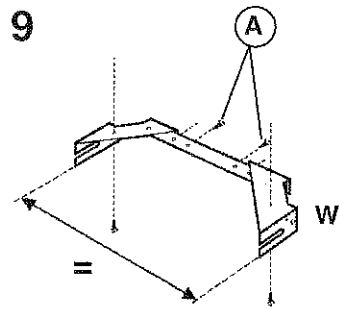

12

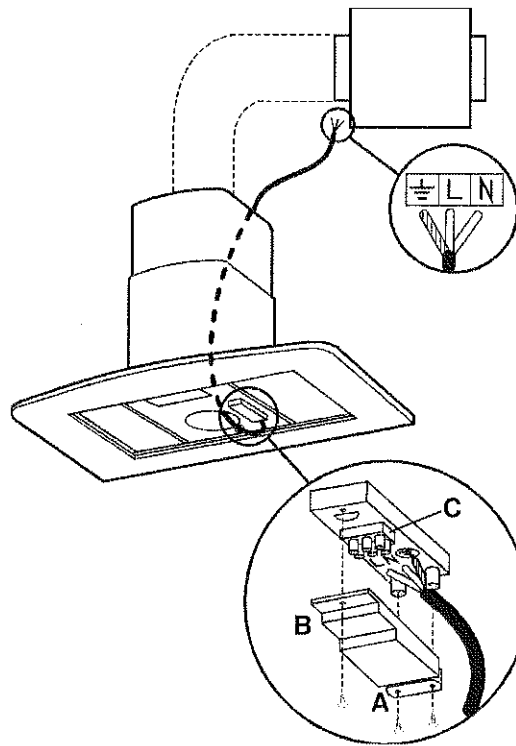
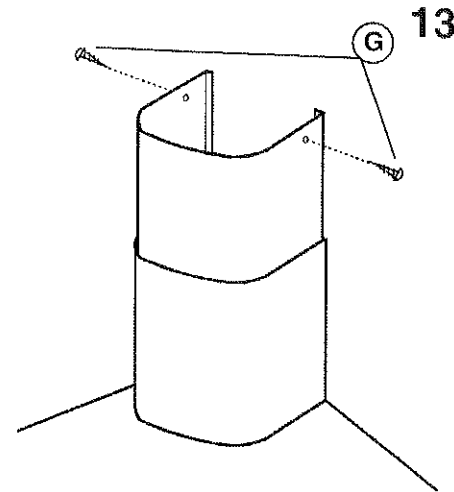

14

15

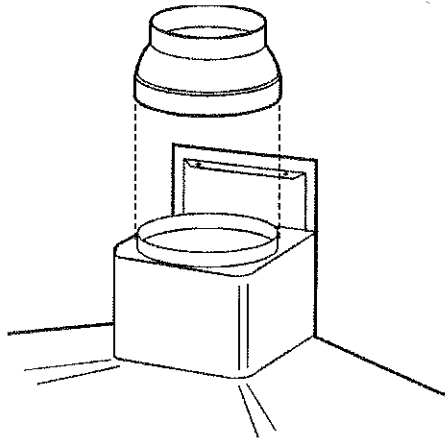

16

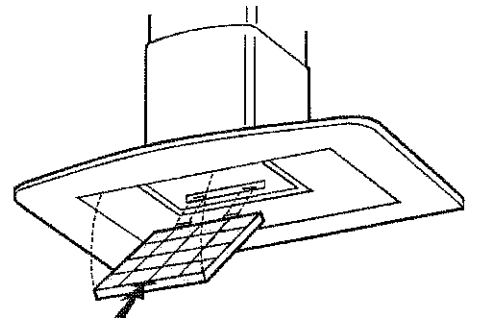

17

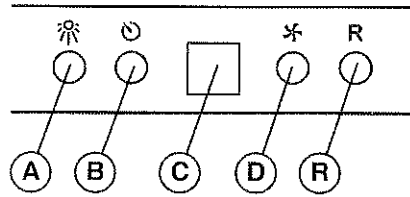

18

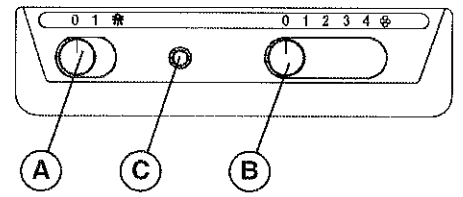

19

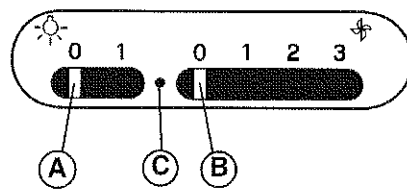

20

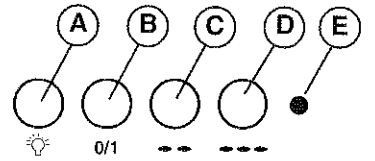

21

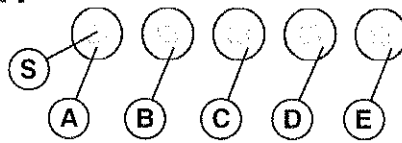

22

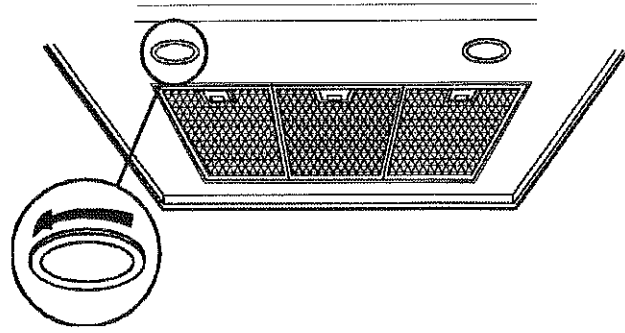

23

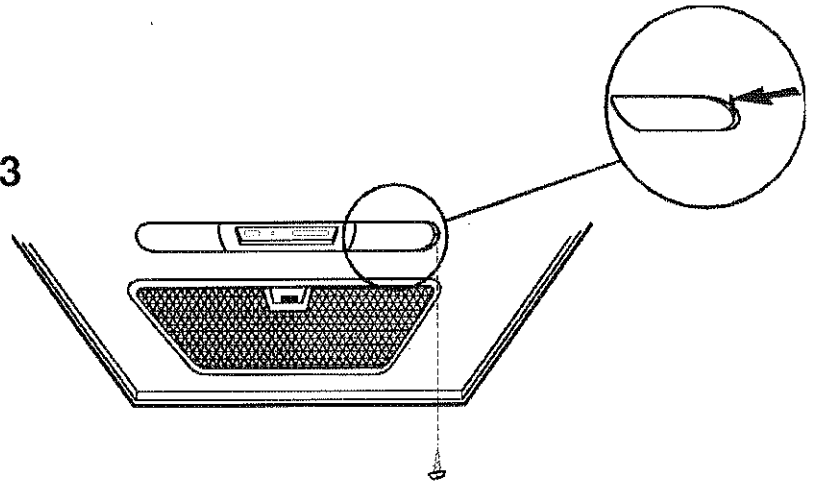

24

