

OG62X cooktop

code OG62X
ID061006

60cm, all gas, four-burner cooktop, includes wok burner & FFD (flame failure device)



optional griddle plates



FINISH	stainless steel, black enamel trivets and burner caps
ACTUAL SIZE	580mmW x 500mmD
CUTOUT	560mmW x 480mmD x 50mmH
INSTALLATION	suits 60cm cabinet, one-piece hob, built-in design
CAPACITY	29.4 mj/hr max over four burners <ul style="list-style-type: none">• 1 x ultra-rapid burner, 13.2 mj/hr max• 2 x semi-rapid burners, 6.3 mj/hr max each• 1 x auxiliary burner, 3.6 mj/hr max
GAS INPUT	<ul style="list-style-type: none">• set for natural gas, regulator supplied• ULPG adaptable, no regulator supplied, ULPG jets and test port supplied
IGNITION	automatic electronic, fitted power cord for 10 amp GPO
FLAME FAILURE DEVICE	flame failure device fitted to each burner
OPTIONS	cast-iron griddle plates — <ul style="list-style-type: none">• rectangular, 36cm x 21.5cm, code 9379• round, 24.5cm diameter, code 9376
WARRANTY	two years parts and labour

FLAME FAILURE DEVICE (FFD)

A flame failure device (FFD) is fitted to each burner assembly. The FFD ensures that should a flame be extinguished prematurely – for instance, by smothering or by a sudden air gust – the gas supply to the specific burner(s) is stopped. For absolute safety, the burners can only be re-ignited by physically resetting the control knob(s) to the 'off' position and then follow normal ignition procedure.

PERFORMANCE

The largest diameter cooking zone with high flame heat output (13.2mj) suits the larger stock pot, wok, saucepan, frypan or griddle and favours more vigorous styles of cooking. Two mid-size all-purpose burners (each 6.3mj) and a small auxiliary burner (3.6mj) for smaller cooking utensils and coffee pots, caters for full versatility in benchtop cooking. All burners can be simply adjusted down for slow simmering by the individual variable controls.

MAINTENANCE

The seamless and moulded hob design allows easy wipe-over cleaning and generous catchment of spills and accidental boil-overs. Trivets, burner caps and burner assemblies are removable and can be washed in warm soapy water. The control knobs can be detached for cleaning access. DO NOT wash any attachments in the dishwasher.

ELECTRONIC IGNITION

The cooktop is connected with a power cord of 1.10 metre length to be plugged into a GPO located according to installation needs below the benchline.

This supplies a continuous stored charge to spark the gas supply to the individual burner(s) of your choice by simply pressing and turning the control knob(s).

GAS PLUMBING

Already adjusted for natural gas, the OG62X gas hob can be converted for ULPG application. This conversion will be made by Omega Appliances provided it is requested at the time of ordering. Otherwise the ULPG jets and a test port are provided.

INSTALLATION

Being of only 50mm displacement and of fully-sealed construction, the OG62X gas hob can be fitted over an oven, drawers, cupboard or even a dishwasher.

CONSTRUCTION

The hob skin is of a single-press indented metal sheet. By moulding the single sheet and avoiding the use of joints before enamelling or the nickel chromium treatment for the stainless steel version, seepage and food debris build-up after cooking is eliminated.

The gas piping is sealed and accessible via a lower skin and displaces only 50mm into the benchtop. For natural gas installation, the regulator fits into an accessible 'free' space adjoining the control panel.

omega

OG62X cooktop

code OG62X
ID061006

60cm, all gas, four-burner cooktop, includes wok burner & FFD (flame failure device)

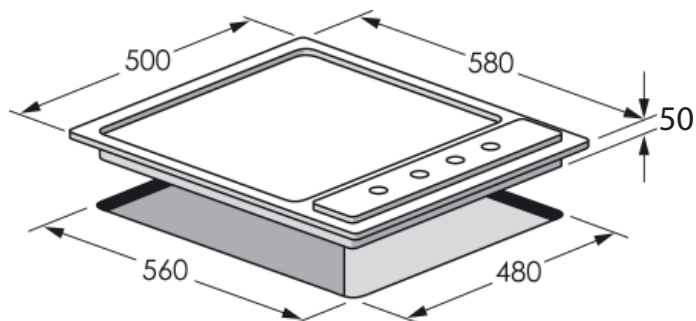

HEIGHT	95mm ● 45mm above bench including trivets ● 50mm below bench
WIDTH	580mm
DEPTH	500mm
CUTOUT	560mmW x 480mmD x 50mmH
PACKAGED DIMENSIONS	645mm x 560mm x 103mm = 0.037m ³
GROSS WEIGHT	8.21kg
NET WEIGHT	7.51kg
MAX GAS INPUT RATE	29.4mj/hr ● ½" BSP gas inlet connection ● gas connection located right-hand rear corner ● ½" BSP 1.0 kPA natural gas regulator is supplied with each natural gas cooktop ● ULPG adaptable, no regulator required ● ULPG jets and test point supplied
IGNITION	● automatic electronic ● 1.1 metre power cord fitted for plugging to standard 10 amp GPO for spark ignition
SUPPLIED	● clips, seal ● instructions for installation, operation, maintenance

NB: drawings are not to scale — they are to assist only

PLAN

FFD: flame failure device fitted to each burner

semi-rapid burners
6.3mj/hr max

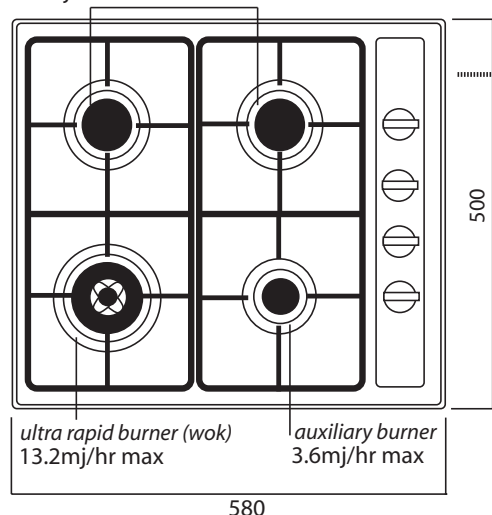

UTILITIES –

rear-right corner, beneath

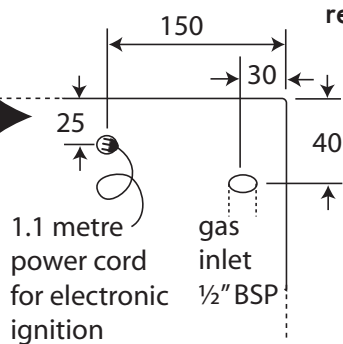

OPTIONS

cast-iron griddle plates

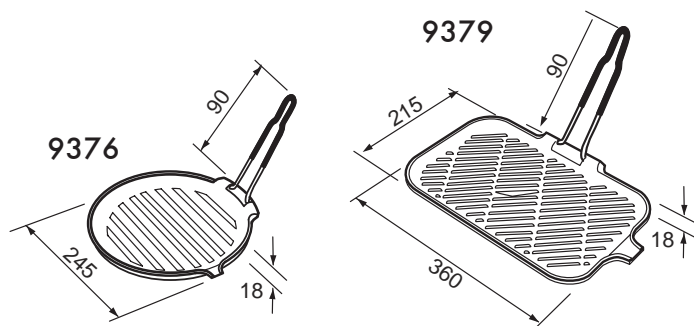

WARNING: technical specifications and product sizes can be varied by the manufacturer without notice. Cutouts for appliances should only be by physical product measurements. The above information is indicative only.

omega