

OG70X cooktop

code OG70X
ID021106

70cm, all gas, five-burner cooktop, includes wok burner, cast-iron trivets & burner caps



optional griddle plates



FINISH	stainless steel, cast-iron trivets and burner caps
ACTUAL SIZE	685mmW x 510mmD
PLEASE NOTE	cutout is only 560mmW x 480mmD x 50mmH
INSTALLATION	one-piece hob, built-in design, cutout requires only standard 60cm cabinet
CAPACITY	40.2 mj/hr max over five burners <ul style="list-style-type: none">● 1 x ultra-rapid burner (wok), 13.2 mj/hr max● 1x rapid burner (wok), 10.8mj/hr max● 2 x semi-rapid burners, 6.3 mj/hr max each● 1 x auxiliary burner, 3.6 mj/hr max
GAS INPUT	<ul style="list-style-type: none">● set for natural gas, regulator supplied● ULPG adaptable, no regulator required, ULPG jets and test port supplied
IGNITION	automatic electronic, fitted power cord for 10 amp GPO
OPTIONS	cast-iron griddle plates — <ul style="list-style-type: none">● rectangular, 36cm x 21.5cm, code 9379● round, 24.5cm diameter, code 9376
WARRANTY	two years parts and labour

SPACIOUS DESIGN

Circumstances might dictate that a standard 60cm four-burner cooktop is too small and the larger 86cm-wide cooktop is impractical. Perhaps the solution is the 68.5cm-wide OG70X, where a spacious cooking area has been realised by moving the controls the front and allowing an increased hob area to 'float' out over the benchtop.

60cm INSTALLATION

Despite occupying 68.5cm of benchtop width, the actual cutout width is only that of a standard 60cm cooktop; that is, the cutout width required is only 56cm. This allows easy fitment into a pre-designed standard 60cm cabinet and makes the OG70X suitable for most of the replacement gas cooktop market.

CENTRAL ULTRA-RAPID (WOK) BURNER

This 3.2 megajoule burner is perfectly positioned for the larger boiler, frypan, griddle plate and wok. Its central design also favours those installations where, having a large utensil on one of the side burners, is restrictive or impossible because a cabinet wall is closely positioned to the side edging of the cooktop.

AUXILIARY (SIMMER) BURNER

With only a maximum of 3.6 megajoules an hour, this small burner can be turned down for the safest continuous low flame. This gentlest of heats is ideal, for example, a Béarnaise sauce or the very slow cook stockpot.

CAST-IRON TRIVETS

Heavy duty and virtually indestructible, these trivets ensure minimal movement and offer a secure, stable surface for the cross-movement of pots, pans etc. The three (3) sections also make for easier washing in a sink in warm soapy water.

ELECTRONIC IGNITION

The cooktop is connected with a power cord of 1.1 metre length to be plugged into a GPO located according to installation needs below the benchline. This supplies a continuous stored charge to spark the gas supply to the individual burner of your choice. Simply depress and turn the control knob of the desired cooking zone for flame ignition.

SEAMLESS CONSTRUCTION

The single press construction of the satin stainless steel hob skin is completely devoid of any screw heads or metal joins. Even the trivets are cast to fit perfectly within the moulded sink of the hob. These trivets are also fitted with non-slip rubber feet to minimise the slightest movement and prevent wear and tear of the hob skin.

LOW MAINTENANCE

Easy cleaning is assured of the seamless hob design. There are no joins or screw head sink holes for grime to accumulate. The deep hob also allows for the easy catchment of even large accidental spills and boil-overs. The knobs also are removable for cleaning access. Trivets, burner caps and assemblies can be washed in warm soapy water.

SPACE SAVING

With only a 50mm displacement into the benchtop, the OG70X allows for easy installation below oven, dishwasher, cupboard or drawers.

omega

OG70X cooktop

code OG70X
ID021106

70cm, all gas, five-burner cooktop, includes wok burner, cast-iron trivets & burner caps

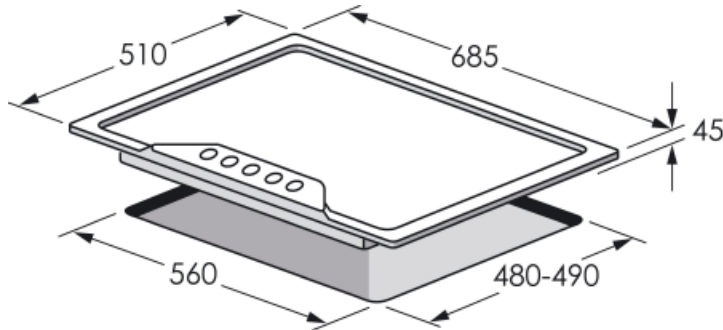

HEIGHT	95mm
	<ul style="list-style-type: none"> • 45mm above bench including trivets • 50mm below bench
WIDTH	685mm
DEPTH	510mm
CUTOUT	560mmW x 490mmD x 50mmH
PACKAGED DIMENSIONS	760mm x 560mm x 110mm = 0.45m ³
GROSS WEIGHT	15kg
NET WEIGHT	12.7kg
MAX GAS INPUT RATE	40.2mj/hr max over five burners
	<ul style="list-style-type: none"> • ½" BSP gas inlet connection • gas connection located below rear-right edge • ½" BSP 1.0 kPA natural gas regulator is supplied with each natural gas cooktop • ULPG adaptable, no regulator required • ULPG jets and test point supplied
IGNITION	<ul style="list-style-type: none"> • automatic electronic • 1.1 metre power cord fitted for plugging to standard 10 amp GPO for spark ignition
SUPPLIED	<ul style="list-style-type: none"> • clips, seal • instructions for installation, operation, maintenance

NB: drawings are not to scale — they are to assist only

UTILITIES — below rear right edge

PLAN

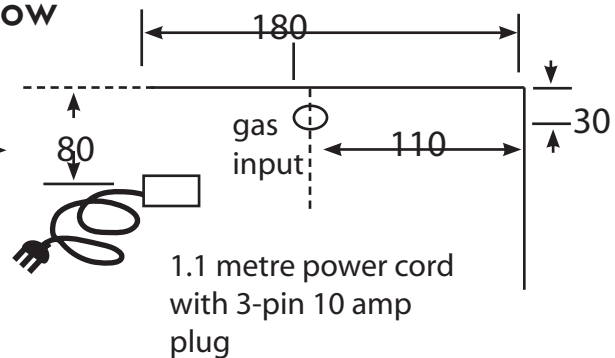
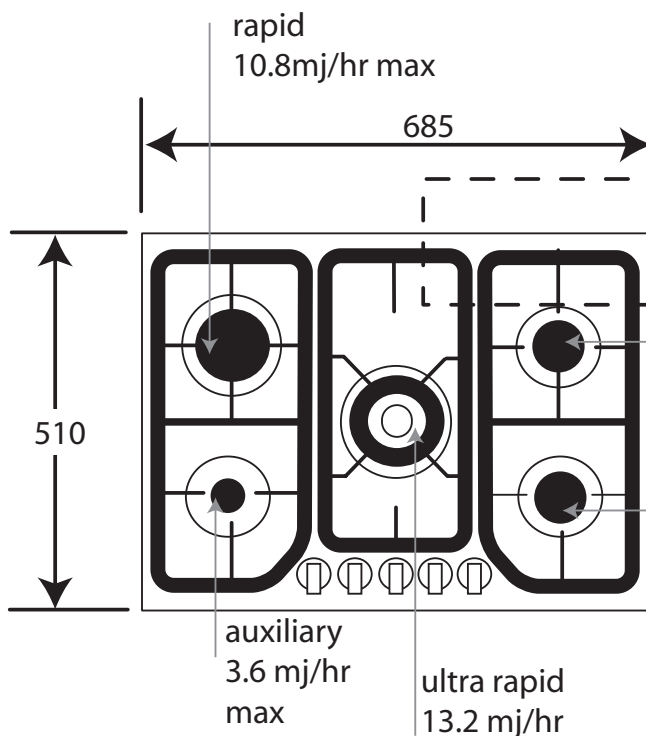

OPTIONS

cast-iron griddle plates

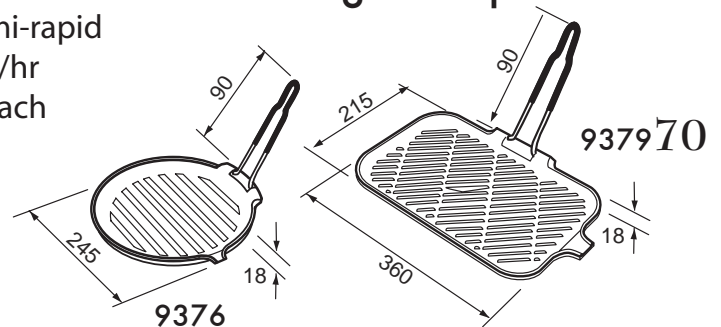

WARNING: technical specifications and product sizes can be varied by the manufacturer without notice. Cutouts for appliances should only be by physical product measurements. The above information is indicative only.

omega