



RANGEHOODS

Omega has a rangehood solution to suit your needs — from undermount and hidden in your cabinetry, to telescopic and wallmount chimney, in 60cm and 90cm widths.

In either a wallmount or island setting, an Omega rangehood is not only powerful and highly functional, but can also be a visual enhancement to any kitchen.

You also have the option to choose to have your Omega rangehood ducted direct to the atmosphere or filtered and recirculated, or have a remote motor installed to reduce sound.

fixed/freestanding

ORF6X



ALSO AVAILABLE IN
WHITE | ORF6W

- 60cm, stainless steel finish
- built-in
- 120W motor
- three speeds plus OFF button
- 2 x 40W incandescent SES tubular globes, separate ON/OFF button
- 270m³/hr max airflow
- 39-62 dBA noise level
- 2 x 4-ply aluminium grease filters — removable, washable
- recirculate or top/rear direct duct to atmosphere
- 120mm dia spigot supplied for ducting
- two years parts and labour warranty

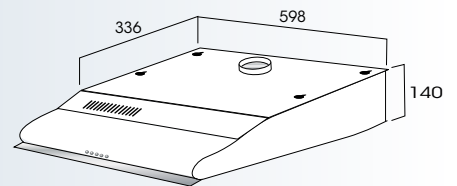

ORF9X



ALSO AVAILABLE IN
WHITE | ORF9W

- 90cm, stainless steel finish
- built-in
- 120W motor
- three speeds plus OFF button
- 2 x 40W incandescent SES tubular globes, separate ON/OFF button
- 270m³/hr max air movement
- 39-62 dBA noise level
- 2 x 4-ply aluminium grease filters — removable, washable
- recirculate or top/rear direct duct to atmosphere
- 120mm dia spigot supplied for ducting
- two years parts and labour warranty

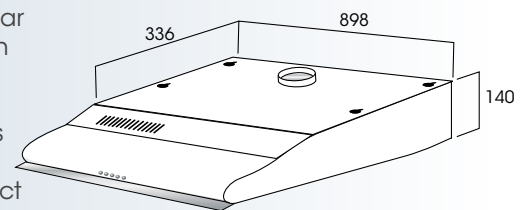

K296X60



ALSO AVAILABLE IN
90cm | K296X90

- 60cm or 90cm stainless steel, glass visor
- freestanding or built-in
- rear or top direct duct to atmosphere or front recirculate to kitchen
- three speeds, separate buttons
- twin motors, 120W each
- 585m³/hr max airflow
- 2 x 40W incandescent lights, separate button
- 4-ply aluminium grease filter, removable and washable
- two years parts and labour warranty

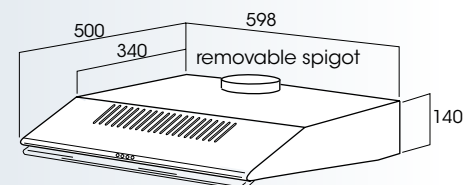

concealed undermount

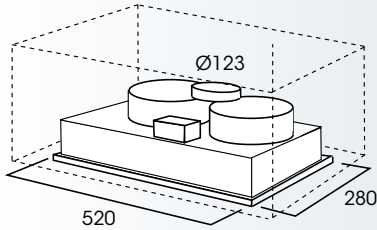

- silverfrost finish
- undermount concealed
- twin motors, 100W each
- 494m³/hr max airflow
- 2 x 40W incandescent globes
- three speeds
- direct duct to atmosphere or recirculate to kitchen
- 125mm dia ducting required
- two years parts and labour warranty



ALSO AVAILABLE IN
70cm | P194-70

P194-52

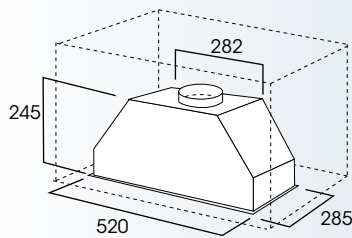

- 52cm all stainless steel
- undermount concealed
- centrifugal motor, 250W
- 530m³/hr max airflow
- duct direct to atmosphere or recirculate to kitchen, 150mm ducting required
- 34-55 dBA
- 2 x 40W incandescent globes four speeds
- 5-minute delay stop selection
- 30-hour use LED prompt to clean filters
- 2 x stainless steel and aluminium 4-ply grease filters, removable and washable



OR521UXB

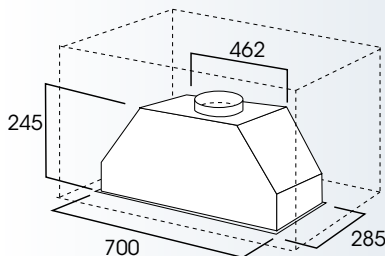

- 70cm all stainless steel
- undermount concealed
- centrifugal motor, 250W
- 530m³/hr max airflow
- duct direct to atmosphere or recirculate to kitchen, 150mm ducting required
- 34-55 dBA
- 2 x 40W incandescent globes
- four speeds
- 5-minute delay stop selection
- 30-hour use LED prompt to clean filters
- 2 x stainless steel and aluminium 4-ply grease filters, removable and washable



OR701UXB

telescopic

SOH1SS



- fascia rail removable and replaceable for full integration
- supplied with 1 x 42mmH stainless steel fascia + 1 x 68mmH stainless steel fascia rail
- single motor, 60W
- 2 speeds
- 2 x 40W SES incandescent globes
- 38-52 dBA
- 350m³/hr max airflow
- one-piece, 3-ply aluminium filter, removable and washable
- 240V, 50Hz
- connected 95cm power cord with 3-pin 10 amp plug
- two years parts and labour warranty

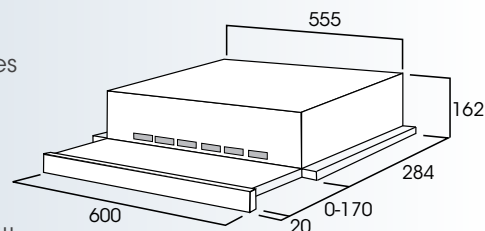

OR601TWA



- 60cm white enamel fascia and deflector
- single motor, 100W
- 338m³/hr max airflow
- twin 40W SES incandescent globes, separate presettable switch
- 3 speeds, presettable switch
- 3-ply aluminium grease filter, removable and washable
- duct direct to atmosphere or recirculate 125mm dia ducting required
- 37-53 dBA

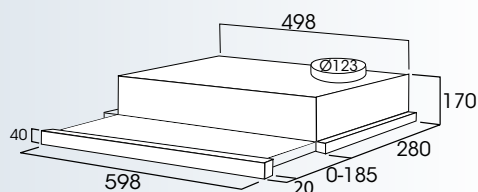

OA416W/X60



- 60cm stainless steel fascia rail, white enamel deflector
- single motor, 100W
- 338m³/hr max airflow
- twin 40W SES incandescent globes, separate presettable switch
- 3 speeds, presettable switch
- removable filter carriage (1 x 60cm, 2 x 90cm)
- 4-ply aluminium grease filter, removable and washable
- duct direct to atmosphere or recirculate 125mm dia ducting required
- 37-53 dBA

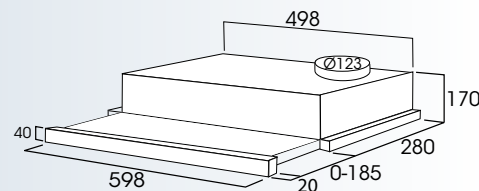

90cm width: 898mm

ALSO AVAILABLE IN
90cm | OA416W/X90

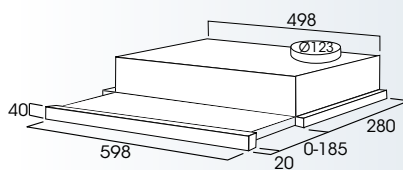

90cm width: 898mm

- 60cm stainless steel fascia rail, white enamel deflector
- twin motors, 100W each
- 507m³/hr max airflow
- twin 40W SES incandescent globes, separate presettable switch
- 3 speeds, presettable switch
- removable filter carriage (1 x 60cm, 2 x 90cm)
- 4-ply aluminium grease filter, removable and washable
- duct direct to atmosphere or recirculate 125mm dia ducting required
- 39-64 dBA



ALSO AVAILABLE IN 90cm | OA2416W/X90

OA2416W/X60

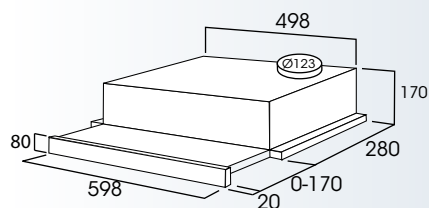

90cm width: 898mm

- 60cm stainless steel fascia rail, white enamel deflector
- single motor, 100W
- 338m³/hr max airflow
- twin 40W SES incandescent globes, separate presettable switch
- 3 speeds, presettable switch
- designed for recirculation, return vent concealed behind 80mm high retractable fascia rail — no ducting required (NB: can be ducted direct to atmosphere, 125mm dia ducting required)
- 37-53 dBA



ALSO AVAILABLE IN 90cm | OR903TWA

OR603TWA

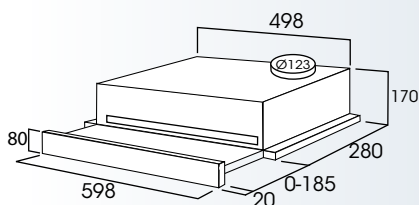

90cm width: 898mm

- 60cm stainless steel fascia rail, glass deflector
- single motor, 100W
- 338m³/hr max airflow
- twin 40W SES incandescent globes, separate presettable switch
- 3 speeds, presettable switch
- removable filter carriage (1 x 60cm, 2 x 90cm)
- 4-ply aluminium grease filter, removable and washable
- designed for recirculation, return vent concealed behind 80mm high retractable fascia rail — no ducting required (NB: can be ducted direct to atmosphere, 125mm dia ducting required)



ALSO AVAILABLE IN 90cm | OA412FRW/X90

OA412FRW/X60

wallmount chimney

OR917CXA



- 90cm stainless steel
- wallmount
- 550m³/hr max airflow
- direct duct to atmosphere or recirculate to kitchen
- 125-150mm diameter ducting material required
- centrifugal motor, 120W
- 2 x 40W incandescent, separate button
- three, separate buttons + ON/OFF switch, light switch
- 3 x aluminium 4-ply grease filters, removable, washable
- 58 dBA
- connected 1.0 metre power cord with 3-pin 10 amp plug

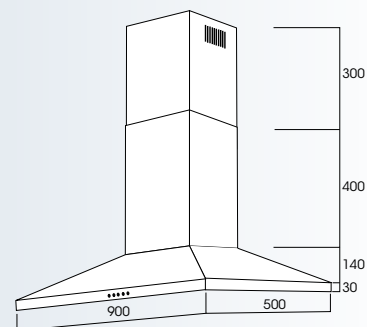

K224/1X90



ALSO AVAILABLE IN
60cm | K224/1X60

- 60cm stainless steel
- wallmount
- centrifugal motor, 198W
- 942m³/hr max airflow
- duct direct to atmosphere or recirculate to kitchen
- 150mm dia ducting required
- twin halogen lights, separate button
- 3 speeds plus OFF, separate buttons
- 44-60 dBA
- 3 x 4-ply aluminium grease filters, removable and washable

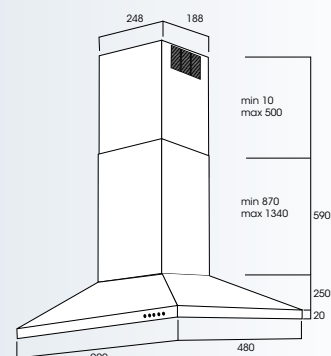

60cm width: 600mm

OR915CXA



- satin stainless steel and glass
- wallmount
- 923m³/hr max airflow
- centrifugal motor, 198W
- direct ducting to atmosphere (NB: not designed for recirculation to kitchen)
- 150mm dia ducting material required
- two 20w halogen, separate button
- three, separate buttons
- 5-minute delay stop selection, separate button
- 2 x aluminium 4-ply grease filters, removable and washable
- 34-56 dBA

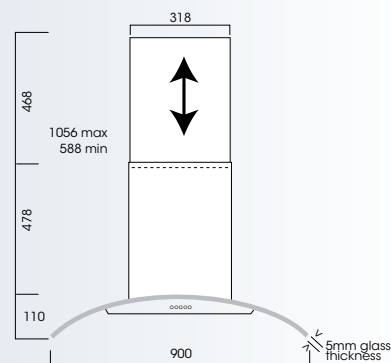

depth: 500mm

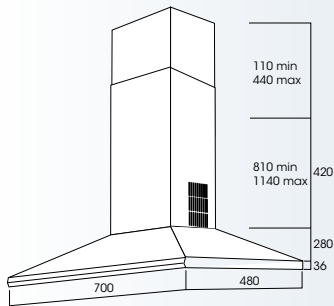

- 70cm stainless steel
- wallmount
- centrifugal motor, 135W
- 663m³/hr max airflow
- duct direct to atmosphere or recirculate to kitchen (150mm ducting required)
- 2 x 40W incandescent lights, separate button
- 3 speeds plus OFF, separate buttons
- 41-53 dBA
- 2 x 4-ply aluminium grease filters, removable and washable



OR701CXA

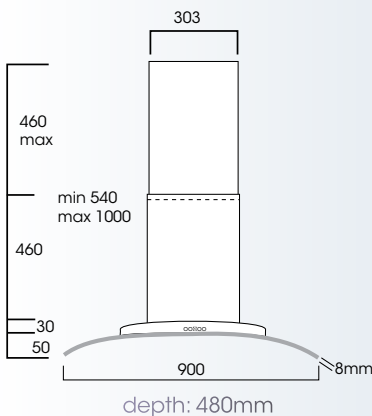

- 90cm stainless steel and 8mm glass
- wallmount
- centrifugal motor, 198W
- 923m³/hr max airflow
- duct direct to atmosphere or recirculate to kitchen (150mm dia ducting required)
- touch control
- two x 20W halogen globes, touch control ON/OFF
- 1-99 minute fan speeds OFF and lights OFF — LED screen
- 1 x stainless steel and 4-ply aluminium grease filter, removable and washable
- 34-56 dBA
- 1.6 metre connected, suits standard 10 amp GPO



OR907CXA

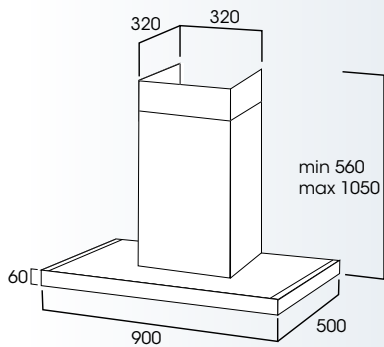

- 90cm stainless steel
- wallmount
- centrifugal motor, 220W
- 910m³/hr max airflow
- duct direct to atmosphere
- twin halogen lights, separate button
- 3 speeds plus OFF, separate buttons
- 5-minute delay stop selection
- 36-59 dBA
- 3 x 6-ply aluminium grease filters, removable and washable



OR911CXA

wallmount chimney

OR912CXA



- 90cm stainless steel
- centrifugal motor, 220W
- 910m³/hr max airflow
- duct direct to atmosphere
- twin halogen lights, touch control
- 3 speeds plus OFF, touch control
- 5-minute delay stop selection
- 36-59 dBA
- 3 x 6-ply aluminium grease filters, removable and washable

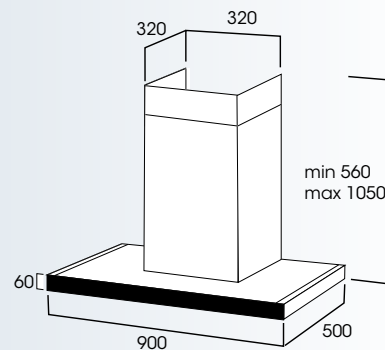

OR914CXA



- 90cm stainless steel, glass canopy
- centrifugal motor, 198W
- 923m³/hr max airflow
- duct direct to atmosphere or recirculate to kitchen (150mm ducting required)
- 2 x 20W halogen globes, separate buttons
- 5-minute delay stop
- 1 x 4-ply aluminium grease filter, removable and washable
- 34-56 dBA
- 1.65m power cable
- 1.0 amp current

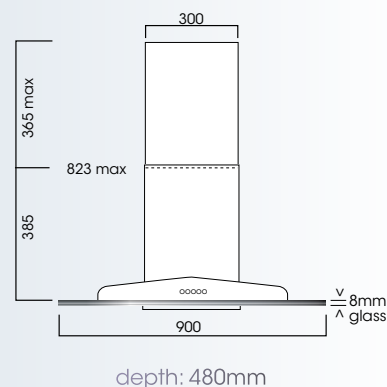

POR905CRXA



- 90cm satin stainless steel
- centrifugal motor, 198W
- 1235m³/hr max airflow
- direct ducting to atmosphere via exterior-mounted motor
- 2 x 20W halogen globes, separate buttons
- 2 x 4-ply aluminium grease filters, removable and washable
- 40 dBA
- 1.7m power cable
- 1.0 amp current

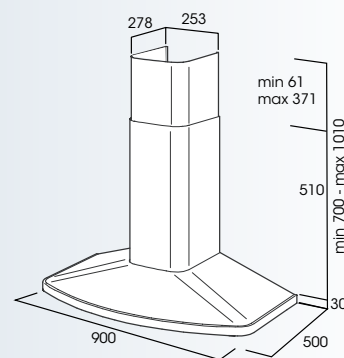

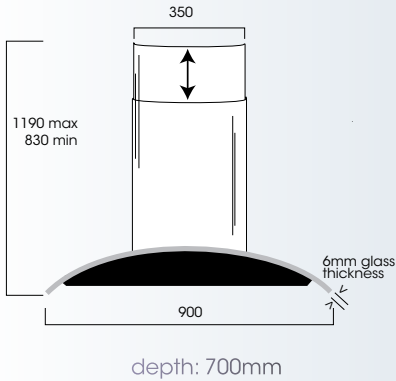

- 90cm stainless, curved glass canopy
- centrifugal motor, 220W
- 900m³/hr max airflow
- duct direct to atmosphere
- 3 speeds, touch control
- 4 x 20W quartz lamps
- 1 x 5-ply aluminium grease filter, removable and washable
- 59 dBA
- 1.6m connected power cable
- 1.0 amp current



OR9001XA

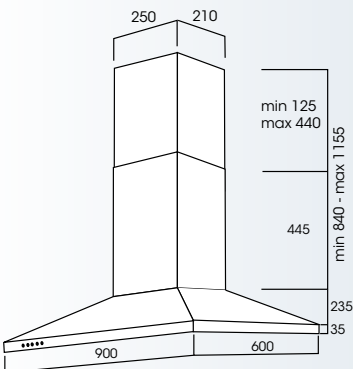

- 90cm stainless steel
- single motor, 190W
- 936m³/hr max airflow
- duct direct to atmosphere
- 4 x halogen lights, separate button
- 3 speeds, separate buttons
- 6 x 4-ply stainless steel/aluminium grease filters, removable and washable



IS20X90



14201 wallplate
650mmW x 600mmH



14202 wallplate
900mmW x 600mmH

- | | |
|--------------|---|
| RAIL60X20/30 | 60cm stainless steel rail, 20x30cm (black: RAIL60BL20X30) |
| RAIL90X20/30 | 90cm stainless steel rail, 20x30cm (black: RAIL90BL20X30) |
| RAIL60X20/40 | 60cm stainless steel rail, 20x40cm (black: RAIL60BL20X40) |
| RAIL90X20/40 | 90cm stainless steel rail, 20x40cm (black: RAIL90BL20X40) |

wallplates | rails

PLEASE NOTE that drawings in this catalogue are not to scale. Specifications may be changed by the manufacturer without notice. It is advised that the product be at hand when measuring for kitchen cabinetry installation to ensure accuracy.