

00727X compact double oven

ID191108
code 00727X

electric, 60cm wide, 72cm high, fan forced & convection, eleven functions, fully automatic



SIZE	594mm W x 720mm H x 561 mm D
FINISH	stainless steel
INSTALLATION	underbench or wall, flush or proud mount
CAPACITY	auxiliary oven — 41.05 litre gross, 33.50 litre net main oven — 53.37 litre gross, 45.26 litre net
FULLY AUTOMATIC	auxiliary oven — minute minder, manual override main oven — programmable digital clock, full auto cooking, minute minder, manual override
THERMOSTAT	0–250° Celsius, both ovens
SAFETY	all furniture safety notched double-glazed door with forced-air door cooling
FURNITURE	2 x baking/roasting/grill trays 2 x grill insert 2 x two chromed-wire shelves wide-grip safety handle for grill tray
WARRANTY	two years parts and labour

OVEN FUNCTIONS

AUXILIARY OVEN



static grill



classic convection



base heat only



light only

MAIN OVEN



fan forced



fan grill



half static grill



baker's function



fan assisted



classic convection



light only

MULTIFUNCTION

fan forced for full capacity, swift and even cooking, suitable for most foods

fan assisted the rear wall fan in conjunction with the outer (perimeter) roof element and the concealed floor element. This function suits most foods and in small quantities

fan grill full capacity or small quantities of meat, poultry, fish, infrared radiant heat from above assisted by the rear fan circulating hot, moist air around the food

static grill both roof elements for full cover and larger capacity grilling

half static grill using only the roof element, the heat is one-directional and is perfect for top browning and very even toasting

baker's function concealed floor element and fan only — perfect for dishes with pastry base and filling. The base heat will finish off the pastry without fear of over-cooking the filling

classic convection gentler cooking for certain food types using only the perimeter roof element and the concealed floor element

base heat only use to crisp pastry bases, use to keep whole oven hot without overcooking

defrost faster thawing is attained in the safe environment of the oven cavity with the continuous circulation of air at a near-ambient temperature

omega

00727X compact double oven

ID191108
code 00727X

electric, 60cm wide, 72cm high, fan forced & convection, eleven functions, fully automatic

OVEN CAPACITIES

auxiliary 210mm H x 460mm W x 425mm D = 41.05 litres gross
188mm H x 440mm W x 405mm D = 33.50 litres net

main 273mm H x 460mm W x 425mm D = 53.37 litres gross
254mm H x 440mm W x 405mm D = 45.26 litres net

MAXIMUM WATTAGE 3675 watts

CURRENT 15.32 amp

NB: must be hard wired, single phase

NB: drawings are not to scale — they are to assist only

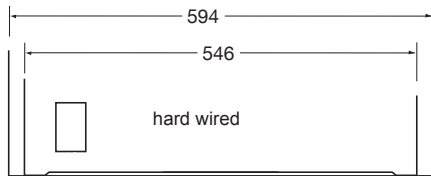

REAR ELEVATION

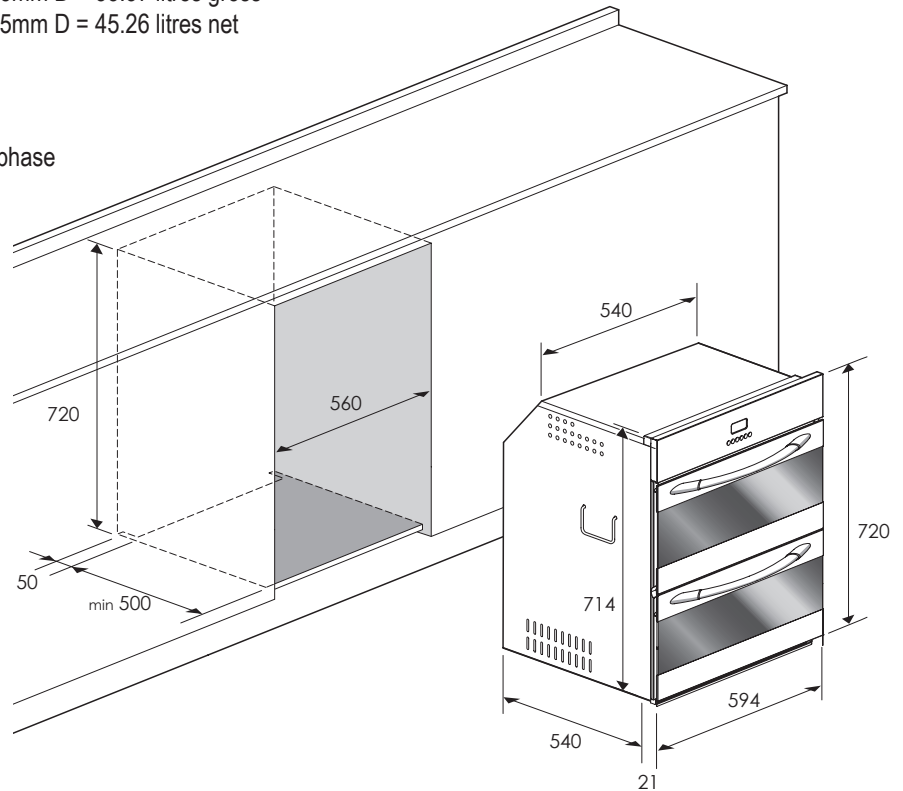

auxiliary oven

main oven

element		roof		floor	rear wall	rear wall fan	cooling fan	light	max wattage	current amp
		inner	outer							
wattage		1000	750	850	1800	25	25	25		
classic convection			•	•			•	•	1650	6.9
base heat only				•			•	•	900	3.6
static grill		•	•				•	•	1800	7.5
wattage		1000	750	850						
fan forced					•	•	•	•	1875	7.9
fan assisted			•	•		•	•	•	1675	7.0
baker's function				•		•	•	•	925	3.9
classic convection			•	•			•	•	1650	6.9
fan grill		•	•			•	•	•	1825	7.7
half static grill		•					•	•	1050	4.4

Warning: technical specifications and product sizes can be varied by the manufacturer without notice. Cutouts for appliances should only be by physical product measurements. The above information is indicative only.

omeg