

00887X double oven

ID081008
code 00887X

electric, 60cm wide, 88.8cm high, fan forced & convection, nine functions, fully automatic



SIZE	888mm H x 594mm W x 561 mm D
FINISH	stainless steel
INSTALLATION	wall mount, flush or proud
CAPACITY	top oven — 41.05 litre gross, 33.50 litre net lower oven — 68.42 litre gross, 59.34 litre net
FULLY AUTOMATIC	top oven — minute minder, manual override lower oven — programmable digital clock, full auto cooking, semi-auto cooking, minute minder, manual override
COOLING FAN	independent carcass cavity cooling fan
SAFETY	anti-tip furniture, double-glazed door with forced air cooling, thermal overload protection
FURNITURE	2 x baking/roasting/grill trays, 2 x grill inserts, 3 x chromed-wire shelves, extra roasting tray, wide-grip safety handle for grill tray
CATALYTIC LINERS	fitted set of three (3) to lower oven
WARRANTY	two years parts and labour
NB:	fitted with thermoreflective flat glass inner door panes to both ovens

OVEN FUNCTIONS

TOP OVEN

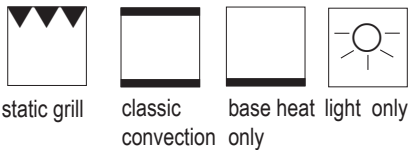

static grill classic convection base heat only light only

LOWER OVEN



fan forced fan grill half static grill baker's function fan assisted classic convection light only

MULTIFUNCTION

- fan forced** for full capacity, swift and even cooking, suitable for most foods
- baker's function** concealed floor element and fan only — perfect for dishes with pastry base and filling. The base heat will finish off the pastry without fear of over-cooking the filling
- fan assisted** the rear wall fan in conjunction with the outer (perimeter) roof element and the concealed floor element. This function suits most foods and in small quantities
- classic convection** gentler cooking for certain food types using only the perimeter roof element and the concealed floor element

- fan grill** full capacity or small quantities of meat, poultry, fish, infrared radiant heat from above assisted by the rear fan circulating hot, moist air around the food
- static grill** both roof elements for full cover and larger capacity grilling
- half static grill** using only the roof element, the heat is one-directional and is perfect for top browning and very even toasting
- base heat only** use to crisp pastry bases, use to keep whole oven hot without overcooking
- defrost** though not indicated, thawing of food is possible by choosing any fan function and the temperature control at zero

00887X double oven

ID081008
code 00887X

electric, 60cm wide, 88.8cm high, fan forced & convection, nine functions, fully automatic

OVEN CAPACITIES

TOP

210mm H x 460mm W x 425mm D = 41.05 litres gross
188mm H x 440mm W x 405mm D = 33.50 litres net

LOWER

350mm H x 460mm W x 425mm D = 68.42 litres gross
333mm H x 440mm W x 405mm D = 59.34 litres net

MAXIMUM WATTAGE

4625 watts

CURRENT

19.27 amp

NB:

must be hard wired, single phase

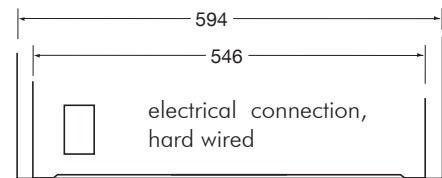
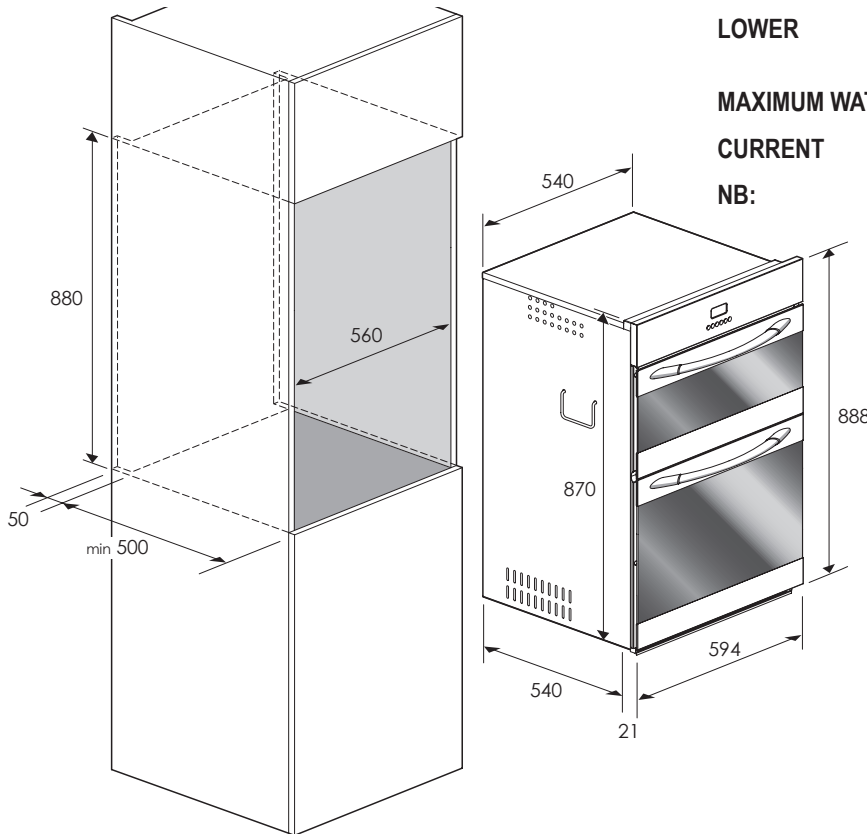

REAR ELEVATION

**NB: drawings are not to scale
— they are to assist only**

	element	roof		floor	rear wall	rear wall fan	cooling fan	light	max wattage	current amp
		inner	outer							
top oven	wattage	1200	1000	1100	2300	25	25	25		
	classic convection		●	●			●	●	2150	8.7
	base heat only			●			●	●	1150	4.8
	static grill	●	●				●	●	2250	9.4
lower oven	wattage	1000	750	850						
	fan forced				●	●	●	●	2375	9.9
	fan assisted		●	●		●	●	●	1675	7.0
	baker's function			●		●	●	●	1175	4.9
	classic convection		●	●			●	●	1650	6.9
	fan grill	●	●			●	●	●	1825	7.6
	half static grill	●					●	●	1050	4.4

omega

Warning: technical specifications and product sizes can be varied by the manufacturer without notice.
Cutouts for appliances should only be by physical product measurements. The above information is indicative only.