

Designed to Enhance  
EST. 1981

**omega**

Installation + User Manual  
OHPD800W

# Heat Pump Clothes Dryer

8kg

# Contents

---

|    |                              |
|----|------------------------------|
| 03 | Welcome                      |
| 04 | Safety Information           |
| 06 | Installation Instructions    |
| 07 | Your Heat Pump Clothes Dryer |
| 08 | Your Control Panel           |
| 09 | Operating Instructions       |
| 11 | Care & Maintenance           |
| 12 | Troubleshooting              |
| 13 | Technical Specifications     |
| 14 | Purchase Details             |
| 18 | Warranty Information         |

# Welcome

---

## Residentia Group

Office 165 Barkly Avenue Burnley  
Victoria Australia 3121

ACN 70 600 546 656

Online [residentia.group](http://residentia.group)  
[omegaappliances.com.au](http://omegaappliances.com.au)

Post PO BOX 5177 Burnley  
Victoria Australia 3121

Phone 1300 11 4357

Email [support@residentia.group](mailto:support@residentia.group)

## Congratulations on purchasing your new Clothes Dryer.

Omega appliances are proudly owned and distributed within Australia by Residentia Group Pty Ltd.

Please refer to the warranty chapter at the rear of this manual for information regarding your product's parts and labour warranty, or visit us online at:

→ [residentiagroup.com.au](http://residentiagroup.com.au)

Here at Residentia Group, we are customer obsessed and our Support Team are there to ensure you get the most out of your appliance. Should you want to learn more about your unit, and importantly, taking care of the appliance, our Support Team are here to help. You can use our online Support Centre at any time by visiting:

→ [support.residentiagroup.com.au](http://support.residentiagroup.com.au)

Or you can contact us by dialling: 1300 11 HELP (4357)

It is important that you read through the following user manual thoroughly, in order to familiarise yourself with the installation and operation requirements of your appliance, and to ensure optimum performance.

Again, thank you for choosing an Omega appliance and we look forward to being of service to you.

Kind Regards,

The Residentia Team

## Customer Care

At Residentia Group, we strongly encourage the use of authentic spare parts to guarantee the best results. When contacting our spare parts team through 1300 11 HELP, or by emailing [parts@residentiagroup.com.au](mailto:parts@residentiagroup.com.au), ensure that you have the model and serial numbers on hand, which are found on your appliances' rating plate.

# Safety Information

---

## Important Safety Instructions

**This appliance must only be installed by a suitably licensed and qualified installer in accordance with the instructions provided. Incorrect installation may result in bodily harm, damage to property, and void the product's warranty.**

- This appliance is intended for domestic use only, used for drying textiles washed with water in the household.
- Do not use this appliance for anything other than its intended purpose. Other uses are not recommended, and may cause fire, electric shock or personal injury.
- The use of attachments is not recommended by the appliance manufacturer and distributor as they may prove hazardous, or cause damage to your appliance.
- Ensure you remove all the packaging, taking care to discard waste responsibly.
- Under absolutely no circumstances should you install or use a damaged appliance.
- Always move the appliance carefully.
- The appliance must always be installed by an authorised technician or similarly qualified person. Please note that the manufacturer is not held responsible for any damage caused by defective placement or installation done by an unauthorised personnel.
- To arrange an authorised technician please contact our friendly support team at 1300 11 HELP (4357).
- **CAUTION:** The appliance must be earthed.
- Ensure the data on the appliance's rating label agrees with the power supply. If not, contact an electrician.
- Always use a correctly installed shockproof socket. Do not use any multi-plug adapters or extension cables.
- Connect the mains plug to the mains socket only at the end of the installation. Make sure that there is access to the mains plug after the installation. Do not connect the appliance plug with a power connection board.
- Do not pull the mains cable to disconnect the appliance. Instead pull the plug portion of the mains cable.
- Never touch the mains cable or plug with wet hands, nor should you touch the dryer with wet hands or feet.
- **WARNING:** If the supply cord is damaged, it must be replaced by the manufacturer or its service agent.
- The manufacturer is not responsible if incorrect installation or use causes injuries and damages.
- Before installing and using your appliance, carefully read the supplied instructions. Always keep the instructions with you for future reference.
- Adults and children must not operate the appliance without supervision if they do not have the physical or mental ability, or if they lack the knowledge and experience required to operate the appliance correctly.
- Never allow children to play with the appliance. Do not allow children to go near the appliance while it is operating without supervision, children must always keep a safe distance from the appliance at all times.
- Under absolutely no circumstances should cleaning and user maintenance be carried out by children.
- This appliance can be used by children aged from 8 years and above and persons with reduced physical, sensory or mental capabilities or lack of experience and knowledge if they have been given supervision or instruction concerning use of the appliance in a safe way and understand the hazards involved.
- **WARNING:** Incorrect repairs are dangerous. Repairs may only be carried out by an authorised service technician or a similarly qualified individual.
- **WARNING:** Do not spray aerosols in the vicinity of this appliance while it is in operation.
- An appropriate power source with reliable earthing must be used. Its earth wire must be buried under the ground and shall not be connected with the public utilities such as city water or gas piping, etc. The earth wire and null wire shall be distinguished and shall not be connected together.
- The maximum mass of dry textile material to be used in the appliance is 8 kilograms.
- The clothes dryer is not to be used for textiles that have been used with industrial chemicals for cleaning.
- Under no circumstances should you dry unwashed items in the clothes dryer.
- **WARNING:** Never stop a clothes dryer before the end of the drying cycle unless all items are quickly removed and spread out so that the heat is dissipated.
- The exhaust air must not be discharged into a flue which is also used to exhaust fumes from appliances which burn gas or other fuels.

## Safety Information

---

- The appliance must not be installed behind a lockable door, a sliding door, or a door with a hinge on the opposite side to that of the tumble dryer. The dryer should never be installed in such a way that fully opening the dryer door is restricted.
- Ensure pets are always kept away from this appliance.
- Oil-affected items can ignite spontaneously, especially when exposed to sources of high heat such as in a clothes dryer. The items become warm, causing an oxidation reaction in the oil, creating heat. If the heat cannot escape, the items can become hot enough to catch fire. Piling, stacking or storing oil-affected textiles can prevent heat from escaping and so it is considered a fire hazard.
- If it is unavoidable that fabrics needed to be dried contain vegetable or cooking oil, or have been contaminated by hair care products, they should first be washed in hot water with extra detergent to reduce, but not eliminate, the hazard.
- Always carefully check that the laundry symbols included on your textile's care tag are compatible with use in a clothes dryer. Common fabric types to avoid placing in your dryer include spandex, silk, leather, wool and clothes with sequins.
- This appliance is for indoor use only. As such, adequate ventilation has to be provided for the appliance.
- Prolonged and intensive use of the appliance may call for additional ventilation, for example the opening of a window, or the installation and use of a ceiling extractor fan.
- The opening of the appliance door must not be obstructed by any objects, including thick carpet.
- Do not stack this dryer on a washing machine without an official Omega stacking kit. If stacking on your washing machine is required, please purchase the relevant parts and organise installation through the manufacturer, its service agent or similarly qualified person in order to avoid hazards.
- Do not lean or put weight on the opened door, or sit on top of the dryer, as this may cause damage to the appliance. Please note that the manufacturer is not held responsible for any damage caused by negligence.
- Do not put any objects on top of the dryer, such as a candle or electric cooker.
- The appliance's lint trap must be cleaned frequently in order to avoid a potential fire hazard. Lint must not be allowed to accumulate in or around the dryer.
- Do not use harsh or abrasive cleaners, or rough or coarse objects to clean the appliance surface, as these tools may scratch and tarnish the surface.
- **WARNING:** Do not use steam cleaners.
- Ensure that this product is disposed of correctly, to prevent any possible damage to the environment and to human health which might otherwise be caused if the appliance were to be disposed of incorrectly.
- This product may not be treated as normal household waste. It should be taken to a collection point for the recycling of electrical and electronic goods.
- As this appliance requires a specialist waste disposal, for further information regarding the treatment, recovery and recycling of this product please contact your local council, your household waste disposal service or the store of purchase.
- To disassemble and remove the appliance, perform the installation instructions in reverse order. Always perform disassembly with two people to avoid risk of injuries. Installation and disassembly must always be carried out by either an authorised service technician, or a similarly qualified person.
- Materials used for packaging the appliance include those that are environmentally friendly and are 100% recyclable. Environmentally materials have been marked and can be identified with the appropriate symbol.
- Always wear appropriate clothing when cooking, such as non-flammable clothes that cover torso, legs and feet.
- This appliance is labeled in compliance with the European directive 2012/19/EC for Waste Electrical and Electronic Equipment (WEEE). By ensuring that this appliance is disposed of correctly, you will help to prevent any possible damage to our environment and to human health, which might otherwise be caused if it were disposed of in the wrong way.
- The symbol on the product indicates that it may not be treated as normal household waste, instead it should be taken to a collection point for the recycling of electrical and electronic goods.
- This appliance requires specialist waste disposal. For further information regarding the treatment, recovery and recycling of this product please contact your local council, your household waste disposal service, or the shop where you purchased the appliance.
- For further questions please contact our support team at 1300 11 4357 or visit [support.residentiagroup.com.au](http://support.residentiagroup.com.au)

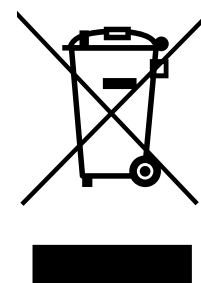

# Installation Instructions

## Important Safety Instructions

- Make sure to check the condition of the appliance after unpacking it. Do not continue with installation if it has been damaged during transport.
- Safe operation of this appliance can only be guaranteed if it has been professionally assembled and installed in accordance with these instructions by a qualified technician.
- The individual who assembled and installed the appliance is liable for damages or faults resulting from an incorrect assembly or installation.
- Installation and maintenance must be carried out by an authorised service agent or similarly qualified technician.
- Ensure power to the appliance has been shut off before carrying out any installation or maintenance.
- **IMPORTANT:** If the power cord is damaged, it must be replaced by Residentia Group or one of its authorised service representatives. Please contact 1300 11 HELP (4357) and ensure the appliance is completely disconnected from the power supply.
- When moving or transporting the appliance, do so cautiously. Do not grasp any salient parts of machine. The machine door cannot be used as the handle for transport. If the dryer cannot be transported upright the dryer can be tilted at an angle of 30°.
- Note that improper handling of the appliance may result in injury, and damaging of the appliance.
- The appliance is very heavy. Never transport or carry the appliance alone; instead always do so with the assistance of at least one other person.
- Remove all obstacles on the transport route and from the installation location, e.g. open doors and clear away objects lying on the floor.
- Do not use the open door as a handhold.
- Remove and responsibly discard of all packaging material before installing or using the appliance. Children can become entangled in the packaging film or swallow small parts and suffocate. Do not allow children to play with the packaging.
- Do not install the clothes dryer in a room where there is a risk of frost occurring. At temperatures around freezing point the appliance may not be able to operate properly. There is a risk of damage if the condensed water is allowed to freeze in the pump and hoses.
- The appliance must not be installed behind a lockable door, a sliding door or a door with a hinge on the opposite side to that of the clothes dryer, in such a way that a full opening of the dryer door is restricted.
- Do not restrict the floor clearance through deep pile carpets, strips of wood or similar. This might cause heat built-up which would interfere with the operation of the appliance.
- It is recommended that, for your convenience, the machine is positioned close to your washing machine.
- The clothes dryer must be installed in a clean place, where dirt does not accumulate. Air must be able to circulate freely around the appliance. Do not obstruct the front air inlet or the air intake grilles at the back of the machine.

## Levelling Procedure

- To keep vibration and noise within minimum level when the dryer is in use, it must be placed on a firm and level surface, and using the adjustable feet must be installed level. Note that the feet must never be removed.
- Once in its permanent operating position, check that the dryer is absolutely level with the aid of a spirit level. If it is not, adjust the feet by hand or using a tool.
- Make sure that the voltage of the power supply is the same as the electric specification.
- Do not connect the dryer with the power connection board, a universal plug or socket, do not use multi-plug adapters and extension cables.

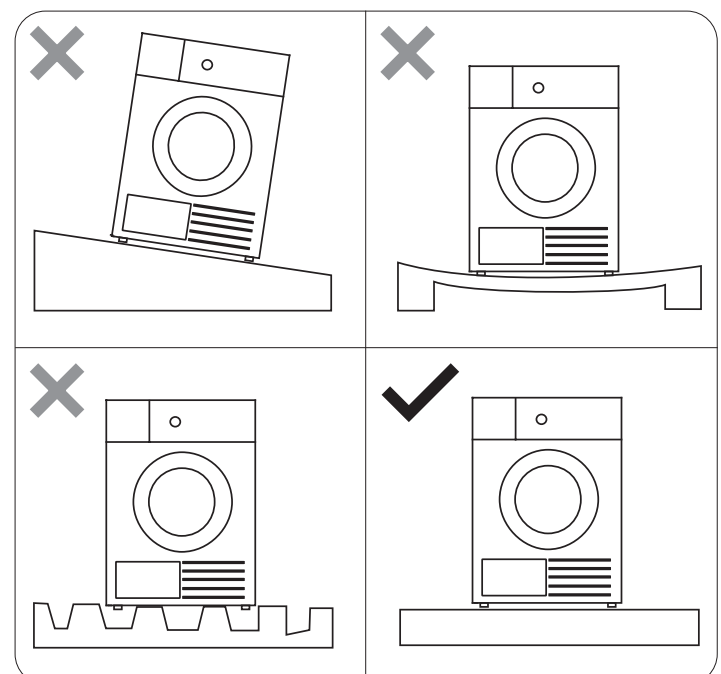

# Your Heat Pump Clothes Dryer

## Product Overview

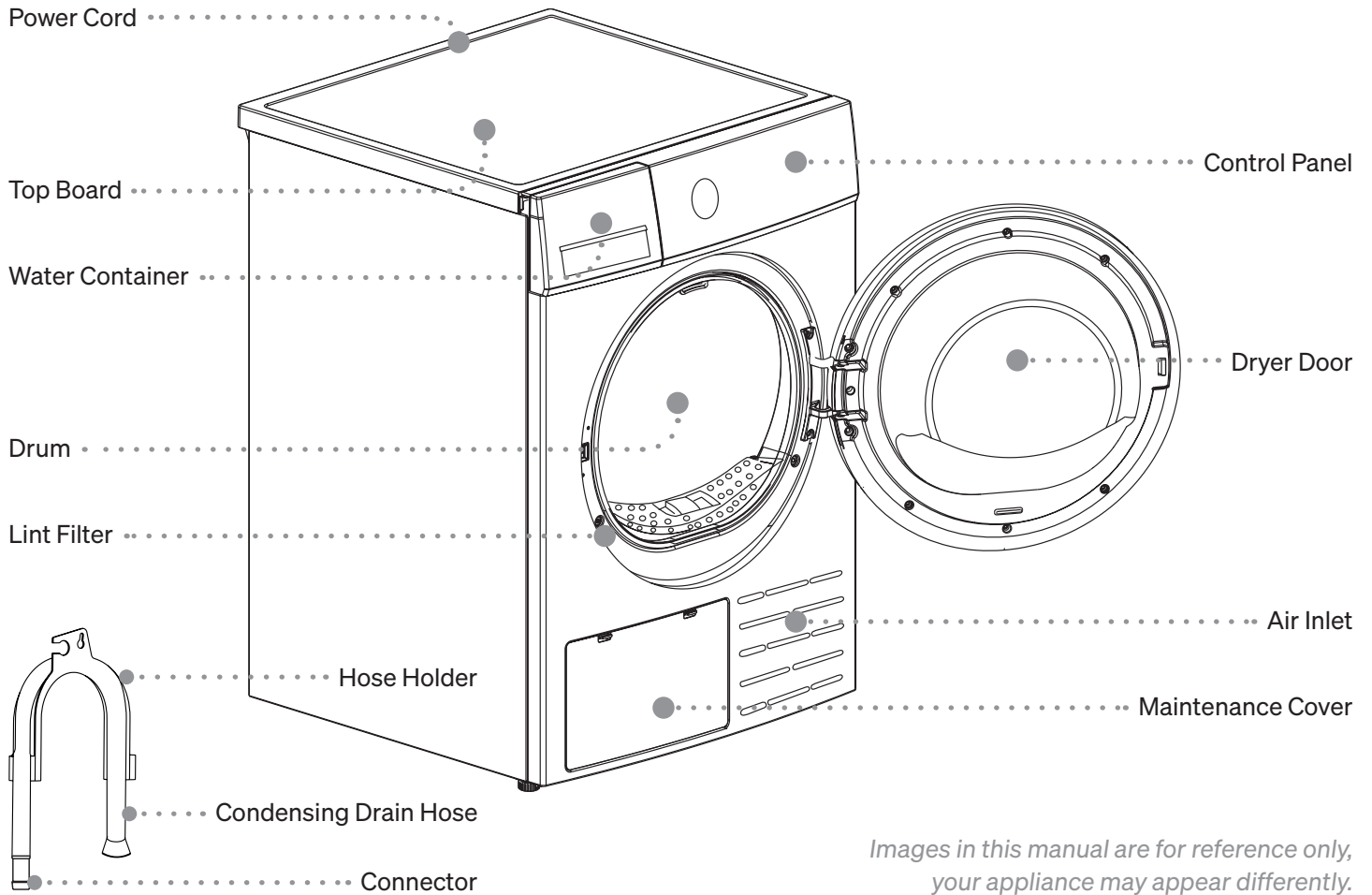

*Images in this manual are for reference only, your appliance may appear differently.*

## Installation Procedure

|  |  |  |  |
|--|--|--|--|
|  |  |  |  |
| <p>1. Begin by pulling up the joint of the drain hose.</p> | <p>2. Next pull up the upper drain hose, avoiding any kinks in the hose.</p> | <p>3. Connect the external drain hose using the hose holder.</p> | <p>4. This can be done either through water drainage or your laundry sink.</p> |

# Your Control Panel

## Control Overview

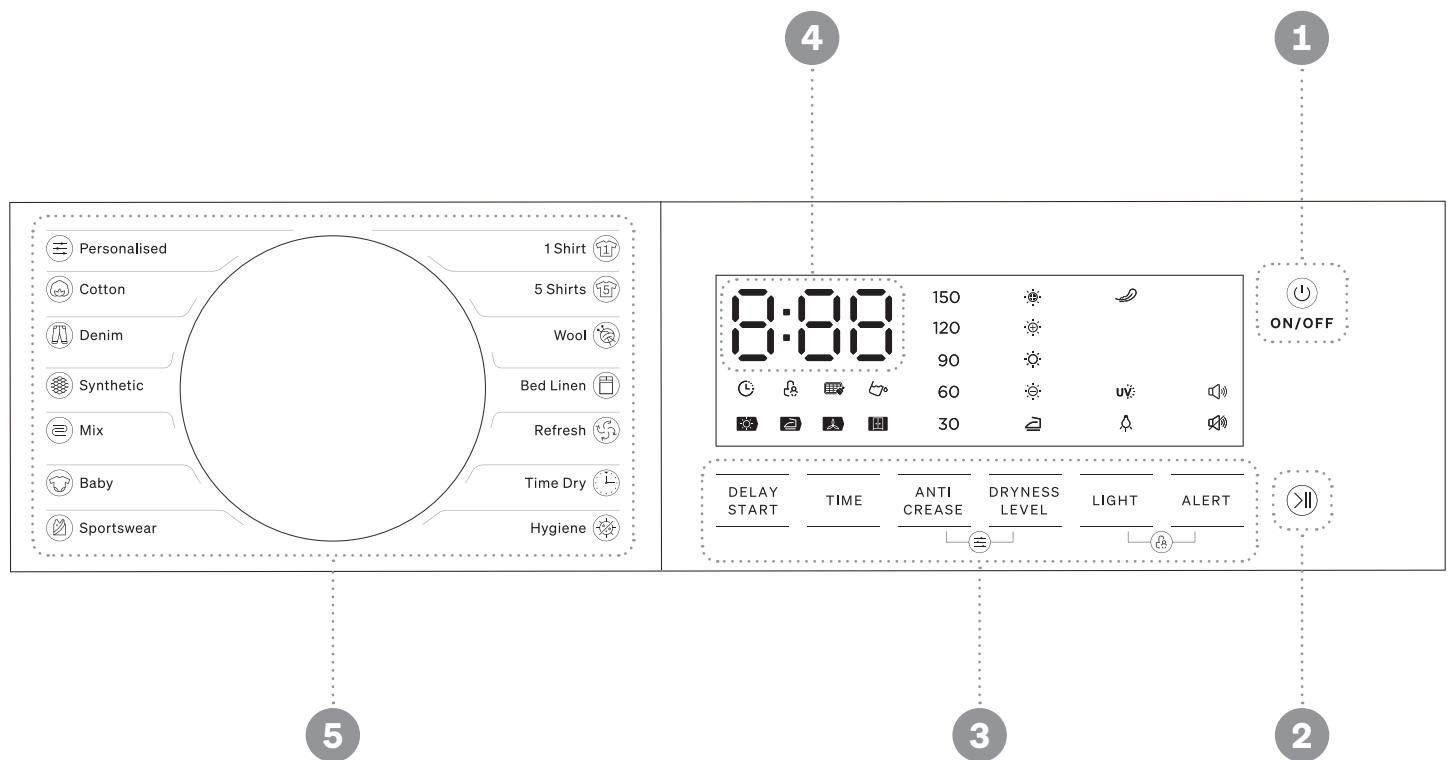

## Controls Key

- 1. On / Off**  
Used to turn the appliance on and off.
- 2. Start / Pause**  
Press this button to start or pause drying at any time during the cycle.
- 3. Additional Functions**  
These buttons are used for setting additional functions or drying options
- 4. LED Display**  
The display shows the current setting, estimated program time remaining, and any relevant status updates.
- 5. Drying Programs**  
The dial is used to select from a range of different drying cycles according to the type of textile(s) being dried.

## Display Key

|     |  |  |                     |
|-----|--|--|---------------------|
|     | <b>Delay Start</b>   |  | <b>Anti-Crease</b>  |
|     | <b>Child Lock</b>  |  | <b>Lamp</b>         |
| 150 | <b>Anti-Crease Time</b><br>(150 min, 120 min, 90 min, 60 min, 30 min)  |  | <b>Iron</b>         |
|     | <b>Clean Lint Filter</b>   |  | <b>Alert On</b>     |
|     | <b>Empty Water Container</b>   |  | <b>Alert Off</b>    |
|     | <b>Cycle Phase</b><br>(Dry, Iron, Cool Down, Cupboard Dry)             |  | <b>UV</b>           |
|     | <b>Dryness Level</b><br>(Ultra Dry, Extra Dry, Standard, Slightly Dry) |  | <b>Personalised</b> |



# Operating Instructions

---

## Operating Your Dryer

1. Before starting the appliance ensure the power plug has been inserted into the socket. Next place your laundry gently inside the drum, ensuring it weighs below the 8kg limit.
2. Close the door carefully, taking care to avoid trapping any items in the door. You can now switch the machine on. The LED display will light up, and you can then select the desired drying program.
3. For additional options you can select the 'Delay', 'Time', 'Dryness Level' and 'Anti-Crease' functions.
4. Finally, press the 'Start / Pause' button and your program will begin, with the display showing the remaining time.
5. Once the program has finished, the drum will stop rotating, the display will show 'END' and a tone will sound.
6. If the load is not removed, the dryer will automatically start an 'Anti-Crease' cycle to avoid clothes creasing.
7. After unloading the dryer, press the 'On / Off' button to power off the appliance. It is also recommended that after finishing you turn off the appliance via the power point.

## Using the Delay Start Function

This function is used for delaying the start of your program until up to 24 hours. When the delayed program starts, the program time will start to countdown and the 'Delay' icon will blink.

1. To use this function, load your laundry as per usual, pressing the 'On / Off' button followed by the program dial to select the desired program.
2. Additionally you can select the 'Anti-Crease' functions or 'Dryness Level' functions if required.
3. Next press the 'Delay' button, each press will increase the amount of time delayed in 10 minute increments.
4. Once the desired time has been chosen, simply press the 'Start / Pause' button. The drying program will begin once the set delay time has elapsed.
5. If you want to cancel the 'Delay' function, simply press the 'On / Off' button and resume from the beginning.

## Extending the Drying Time

Compatible with both the 'Time Dry' and 'Refresh' programs, the 'Time' button can be used to lengthen the program's run time in 10 minute increments, for added convenience.

## Increasing the Level of Dryness

To adjust the dryness of your laundry, press 'Dryness Level', each press increases the drying intensity. This function pairs with all programs except for: 'Time Dry', 'Hygiene', 'Wool' and 'Refresh'. Dryness can only be adjusted before a program starts.

## Using the Lamp Function

The internal drum light turns on for 1 minute once the 'Lamp' button is pressed, or automatically if the dryer door is opened.

## Deactivating UV Hygiene

UV Hygiene is on by default for the 'Bed Linen', 'Sports', 'Baby Care', 'Mix', 'Synthetic' and 'Hygiene' programs, and helps to eliminate harmful bacteria. Pressing the 'Light' for 3 seconds will disable the function. Please note that UV cannot be disabled for 'Hygiene'.

## Muting and Unmuting Your Dryer

By default, your dryer emits a buzzer tone to signify certain alerts. You can mute alerts by pressing the 'Sound' button, and the display will then show the 'Sound Off' symbol signifying that alerts have been disabled. Press 'Sound' to unmute if required.

## Programming 'Personalised'

This function is used to define and save your favourite program and settings, streamlining the drying process in the future.

1. To set your 'Personalised' begin by selecting the desired program and any additional functions.
2. Press both 'Anti-Crease' and 'Fibre-Master' for 3 seconds until a tone sounds, indicating your settings are now saved.
3. From then on, turning the dial to select the 'Personalised' program will return to the previously saved settings. Simply repeat both steps 1. and 2. to edit your settings.

## Activating the Child Lock

The child safety lock is used to prevent unwanted operation.

1. To activate the child safety lock, hold 'Lamp' and 'Sound' at the same time for 3 seconds. A small lock icon will show on the display indicating the lock has been set. All buttons will be deactivated except for the 'On / Off' button.
2. To deactivate the lock function, hold the 'Lamp' and 'Sound' buttons again at the same time for 3 seconds.

## Operating Instructions

### Drying Programs Table

| Program      |               | Max Load | Application   | Delay | Time |
|--------------|---------------|----------|---|-------|------|
| Personalised |               | —        | Define and save your favourite program.   | ✓     | —    |
| Cotton       | Standard<br>☐ | 8.0kg    | For single or multi-layer cotton laundry, to be dried completely for immediate storage.   | ✓     | ✗    |
| Cotton Extra |               |          |   | ✓     | ✗    |
| Synthetic    | Standard      | 3.5kg    | To dry thin, synthetic textiles which are not ironed, such as easy care shirts, baby clothes or socks.  | ✓     | ✗    |
| Mix          |               | 3.5kg    | For a mixed range of fabrics, from cotton to synthetics.  | ✓     | ✗    |
| Baby         |               | 1.0kg    | Used to dry a small amount of baby clothing.  | ✓     | ✗    |
| Sportswear   |               | 3.0kg    | To dry sportswear and thin fabrics such as polyester, provided they are not ironed.   | ✓     | ✗    |
| 1 Shirt      |               | 0.2kg    | For this program, place clothes loosely in the drum. Once dried, remove the garments and quickly hang them on a clothes hanger. Ideal for reducing the amount of ironing required for garments such as shirts.                      | ✓     | ✗    |
| 5 Shirts     |               | 1.0kg    |   | ✓     | ✗    |
| Wool         |               | 1.0kg    | Helps refresh wool items to make them fresh and fluffy.   | ✓     | ✗    |
| Bed Linen    |               | 4.0kg    | Used to dry bed sheets, linen and other larger textiles.  | ✓     | ✗    |
| Refresh      |               | 1.0kg    | Refreshes clothes that have been folded for a long time, to reduce creases. For best results operate between 20 minutes up to 180 minutes max.  | ✓     | ✓    |
| Time Dry     |               | —        | For drying individual items or to complete the drying process multi-layer fabrics with different drying behaviours, such as jackets, pillows or other voluminous items. For best results operate between 10 to 150 minutes maximum. | ✓     | ✓    |
| Hygiene      |               | 5.0kg    | Used to sterilise clothing, especially long-term heat resistant clothing. Fine, sheer or delicate fabrics are not recommended to be used with this program.   | ✓     | ✗    |

**Note for Test Institutes:** “Cotton Extra” program tested in accordance with Regulation AS/NZS 2442.2 for energy labelling, measured in accordance with AS/NZS 2442.1 and suitable for drying normal cotton loads at the rated load capacity.

## Care & Maintenance

### Tips for Cleaning Your Dryer

Clean the dryer with a clean, damp cloth only. Do not use any solvent, abrasive cleaners, glass or all-purpose cleaners, as these sprays can damage plastic surfaces and other parts. Always wear gloves while cleaning to maintain safety.

For best results prepare a clean, damp cloth. Clean the door, especially the inside window. Next clean the sealing around the door opening, followed by the humidity sensor inside the drum. Following the guide included on this page, remove the lint filter and clean it as instructed. Finally, before starting the dryer ensure you dry all parts using a separate, soft and dry cloth.

### Emptying the Water Container

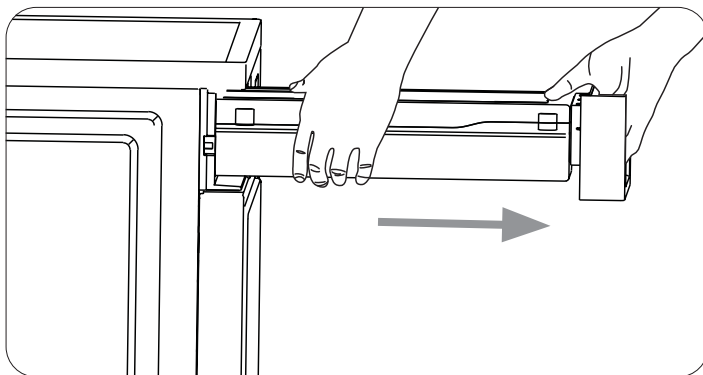

1. Gently pull out the water container, making sure to keep it level with both hands.

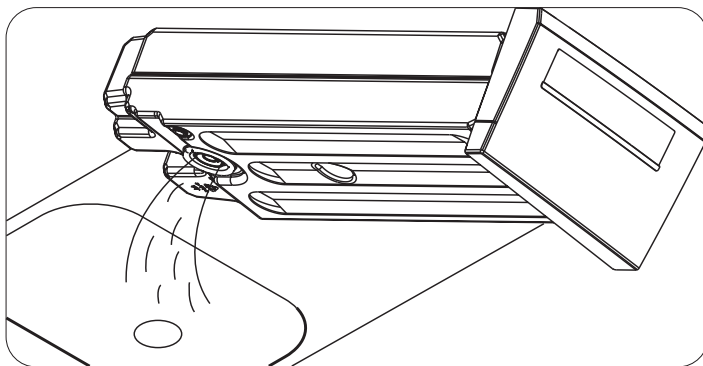

2. Next, slowly tilt the water container over an empty sink to pour out the condensate water. Gently reinstall the water container once it has been fully emptied.

**WARNING:** Always empty the water container after each use. Once the water container is filled completely, the program will be paused and the 'Empty Water Container' icon will light. After the container is emptied, the dryer can be restarted by pressing 'Start/Pause' button.

**WARNING:** Do not under any circumstances use the dryer without the water container. Never drink the condensate water.

### Cleaning the Lint Filter

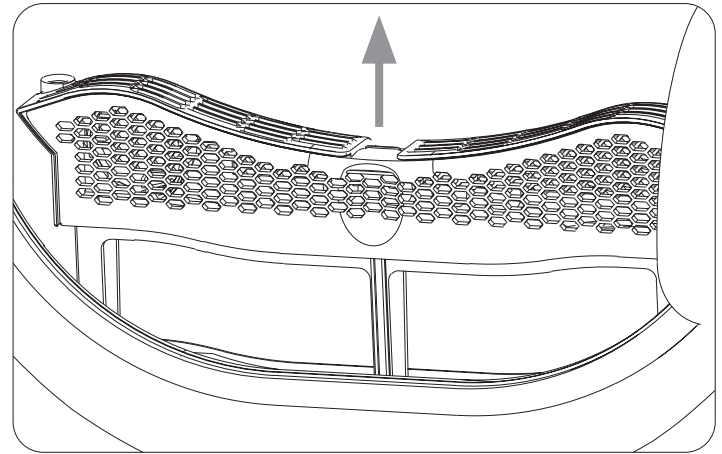

1. To clean the lint filter, first open the dryer door. You will notice the built in lint filter at the base of the opening, which can be easily lifted up.
2. Next open up the filter gently, and using your hands, a soft brush or a small vacuum remove the lint on the filters. If the lint is particularly dusty, you can use water to help.
3. Take extra notice of the correct orientation of the filter before reinserting. Ensure the filter is dry before reinstalling.

**WARNING:** The lint accumulated on the filter will block air circulation inside the dryer. Not cleaning the filter regularly will increase the time it takes for clothes to dry, and increase energy consumption. Ensure you clean the filter at least once a week.

**WARNING:** Never under any circumstances should you operate the dryer without the lint filter equipped.

### Cleaning the Heat Exchanger

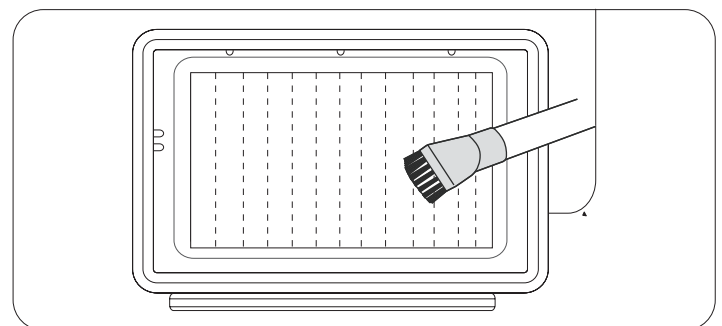





Every 6 months, lint from the heat exchanger must be removed using a vacuum cleaner with a dusting brush attached, using very little pressure. If the exchanger has not been cleaned, it can eventually be damaged and the appliance will not dry.

**WARNING:** Do not touch the heat exchanger directly with your hands as it may cause injuries.

## Troubleshooting

### For Minor Faults

| Problem  | Solution  |
|--|---|
| The display is not turning on.   | <ul style="list-style-type: none"> <li>• Check if the mains power plug has been properly inserted and the power is on.</li> <li>• Check if there is a power outage in your home or area. If the problem persists contact our Support Team for guidance.</li> </ul>  |
| The  symbol is lit on the display.  | <ul style="list-style-type: none"> <li>• Check the water container. If it is full, pour out the condensate water, reinsert the water container and then restart the dryer.</li> <li>• If the  icon is still appearing despite the water container being empty, we recommend that you contact our Support Team for guidance.</li> </ul> |
| The  symbol is lit on the display. | <ul style="list-style-type: none"> <li>• Check the lint filter. Carefully remove the filter and clean the accumulated lint. After reinserting the filter, restart your dryer.</li> <li>• If the  icon is still appearing despite the lint filter being clean, we recommend that you contact our Support Team for guidance.</li> </ul> |
| The drying program is not starting.  | <ul style="list-style-type: none"> <li>• Check if the mains power plug has been properly inserted and the power is on.</li> <li>• See if the water container is full. Additionally, check if the lint filter is clean.</li> <li>• Ensure that the dryer door is properly closed, and no garments are snagged.</li> <li>• Restart the dryer, however if the problem persists contact our Support Team.</li> </ul>        |
| The drying program either took too long or the clothes were not dry enough.  | <ul style="list-style-type: none"> <li>• See if the water container is full. Additionally, check if the lint filter is clean.</li> <li>• Consider using a higher drying intensity level, or alternatively use the Time Dry program to extend the time clothes are spent drying.</li> <li>• Ensure you are not attempting to dry over the appliance's maximum capacity.</li> </ul>                                       |
| There are humming noises while running.  | <ul style="list-style-type: none"> <li>• The compressor is operating. This is normal and does not indicate a fault.</li> </ul>  |
| The dryer turns off after a program ends.  | <ul style="list-style-type: none"> <li>• This is normal, as the appliance turns off automatically in order to save energy.</li> </ul>   |

### For Serious Faults:

- If you experience one of the listed faults shown in the table on page 13, or if another emergency or serious fault occurs, immediately power off the dryer using the controls, and then disconnect the power from the source.
- If a serious fault occurs, DO NOT attempt any repairs yourself, instead wait for a service agent to do so.
- For assistance or to organize an authorised service agent contact our After Sales Support by calling 1300 11 4357, or by emailing support@residentiagroup.com.au.
- Please note that if a service agent is asked to attend whilst the product is under warranty and finds that the problem is not the result of an appliance fault, then you may be liable for the cost of the call out charge.
- The appliance must be accessible for the service agent to perform any necessary repair. If your appliance is installed in such a way that a service agent is concerned that damage will be caused to the appliance or your home, then they will not complete a repair.
- Please refer to the Warranty Information to learn more.

## Technical Specifications

### Specifications Chart

|                         |                   |
|-------------------------|-------------------|
| Model No.               | OHPD800W          |
| Rated Capacity          | 8.0kg             |
| Rated Input Power       | 800W              |
| Rated Voltage           | 220–240V ~        |
| Rated Frequency         | 50Hz              |
| Ambient Temperature     | +2° C ~ +35° C    |
| Refrigerant             | R290              |
| Quantity of Refrigerant | 120g              |
| GWP Rating              | 3                 |
| CO <sup>2</sup> – eq    | 0.00t             |
| Net Weight              | 41kg              |
| Size (W, D, H)          | 600 × 595 × 845mm |

### Drying Fault Codes

| Fault Code | Possible Cause  | Solution  |
|------------|---|---|
| 'E32'      | A fault has occurred with the dryer's humidity sensor.          | <ul style="list-style-type: none"> <li>Take note of the fault code and please call our Support Team by dialling 1300 11 4357 or email at support@residentiagroup.com.au</li> <li>Next, remove the power plug from the wall immediately.</li> <li>To avoid any damage to the appliance, risk of bodily harm or property damage, do not attempt to carry out any repairs yourself, instead wait for a service agent.</li> </ul> |
| 'E33'      | A fault has occurred with the dryer's temperature sensor.       |   |
| 'E82'      | A PCB (printed circuit board) communication error has occurred. |   |

**Note:** These fault codes will only appear if an abnormality or fault occurs. In such an occurrence, the appliance will enter a protective state and display one of the relevant fault codes as listed above. Do not ignore these codes if they appear.

## Purchase Details

Attach your receipt to this page

---

For future reference, please record the following information which can be found on the rating plate and the date of purchase which can be found on your sales invoice.

### Store Details

Store Name

---

Address

---

Telephone

| Purchase Date

---

### Product Details

Model No.

---

Serial No.

---









## Warranty Information

---

### WARRANTY TERMS AND CONDITIONS LAUNDRY APPLIANCES

This document sets out the terms and conditions of the product warranties for Residentia Group Appliances. It is an important document. Please keep it with your proof of purchase documents in a safe place for future reference should you require service for your Appliance.

1. In this warranty
  - (a) 'acceptable quality' as referred to in clause 10 of this warranty has the same meaning referred to in the ACL;
  - (b) 'ACL' means Trade Practices Amendment (Australian Consumer Law) Act (No.2) 2010;
  - (c) 'Appliance' means any Residentia Group product purchased by you accompanied by this document;
  - (d) 'ASR' means Residentia Group authorised service representative;
  - (e) 'Residentia Group' means Residentia Group Pty Ltd of 165 Barkly Ave, Burnley VIC 3121, ACN 70 600 546 656 in respect of Appliances purchased in Australia;
  - (f) 'major failure' as referred to in clause 10 of this warranty has the same meaning referred to in the ACL and includes a situation when an Appliance cannot be repaired or it is uneconomic for Residentia Group, at its discretion, to repair an Appliance during the Warranty Period;
  - (g) 'Warranty Period' means:
    - (i) where the Appliance is used for personal, domestic or household use (i.e. normal single family use) as set out in the instruction manual, the Appliance is warranted against manufacturing defects for 24 months, following the date of original purchase of the Appliance;
    - (h) 'you' means the purchaser of the Appliance not having purchased the Appliance for re-sale, and 'your' has a corresponding meaning.
2. This warranty only applies to Appliances purchased and used in Australia and is in addition to (and does not exclude, restrict, or modify in any way) any non-excludable statutory warranties in Australia.
3. During the Warranty Period Residentia Group or its ASR will, at no extra charge if your Appliance is readily accessible for service, without special equipment and subject to these terms and conditions, repair or replace any parts which it considers to be defective. Residentia Group or its ASR may use remanufactured parts to repair your Appliance. You agree that any replaced Appliances or parts become the property of Residentia Group. This warranty does not apply to light globes, batteries, seals, filters or similar perishable parts.
4. Parts and Appliances not supplied by Residentia Group are not covered by this warranty.

## Warranty Information

---

5. You will bear the cost of transportation, travel and delivery of the Appliance to and from Residentia Group or its ASR. If you reside outside of the service area, you will bear the cost of:
    - (a) travel of an authorised representative;
    - (b) transportation and delivery of the Appliance to and from Residentia Group or its ASR, in all instances, unless the Appliance is transported by Residentia Group or its ASR, the Appliance is transported at the owner's cost and risk while in transit to and from Residentia Group or its ASR.
  6. Proof of purchase is required before you can make a claim under this warranty.
  7. You may not make a claim under this warranty unless the defect claimed is due to faulty or defective parts or workmanship. Residentia Group is not liable in the following situations (which are not exhaustive):
    - (a) the Appliance is damaged by:
      - (i) accident
      - (ii) misuse or abuse, including failure to properly maintain or service
      - (iii) normal wear and tear
      - (iv) power surges, electrical storm damage or incorrect power supply
      - (v) incomplete or improper installation
      - (vi) incorrect, improper or inappropriate operation
      - (vii) insect or vermin infestation
      - (viii) failure to comply with any additional instructions supplied with the Appliance;
    - (b) the Appliance is modified without authority from Residentia Group in writing;
    - (c) the Appliance's serial number or warranty seal has been removed or defaced;
    - (d) the Appliance was serviced or repaired by anyone other than Residentia Group, an authorised repairer or ASR.
  8. This warranty, the contract to which it relates and the relationship between you and Residentia Group are governed by the law applicable where the Appliance was purchased.
  9. To the extent permitted by law, Residentia Group excludes all warranties and liabilities (other than as contained in this document) including liability for any loss or damage whether direct or indirect arising from your purchase, use or non use of the Appliance.
  10. For Appliances and services provided by Residentia Group in Australia, the Appliances come with a guarantee by Residentia Group that cannot be excluded under the Australian Consumer Law. You are entitled to a replacement or refund for a major failure and for compensation for any other reasonably foreseeable loss or damage. You are also entitled to have the Appliance repaired or replaced if the Appliance fails to be of acceptable quality and the failure does not amount to a major failure. The benefits to you given by this warranty are in addition to your other rights and remedies under a law in relation to the Appliances or services to which the warranty relates.
  11. At all times during the Warranty Period, Residentia Group shall, at its discretion, determine whether repair, replacement or refund will apply if an Appliance has a valid warranty claim applicable to it.
  12. Missing parts are not covered by warranty. Residentia Group reserves the right to assess each request for missing parts in a case by case basis. Any parts that are not reported missing in the first week after purchase will not provide free of charge.
  13. To enquire about claiming under this warranty, please follow these steps:
    - (a) carefully check the operating instructions, user manual and the terms of this warranty;
    - (b) have the model and serial number of the Appliance available;
    - (c) have the proof of purchase (e.g. an invoice) available;
    - (d) telephone the numbers shown below.
  14. You accept that if you make a warranty claim, Residentia Group and its ASR may exchange information in relation to you, in order to enable Residentia Group to meet its obligations under this warranty.
- 
- IMPORTANT**  
Before calling for service, please ensure the steps in point 13 have been followed.
- CONTACT SERVICE**  
1300 11 HELP (4357)  
support@residentiagroup.com.au

**The Australian Consumer Law requires the inclusion of the following statement with this warranty:**

Our goods come with guarantees that cannot be excluded under the Australian Consumer Law. You are entitled to a replacement or refund for a major failure and for compensation for any other reasonably foreseeable loss or damage. You are also entitled to have the goods repaired or replaced if the goods fail to be of acceptable quality and the failure does not amount to a major failure.



EST. 1981

# Designed to Enhance

**omega**

Omega is proudly owned in Australia  
by Residentia Group Pty. Ltd.

@residentia.group  
[www.residentia.group](http://www.residentia.group)